

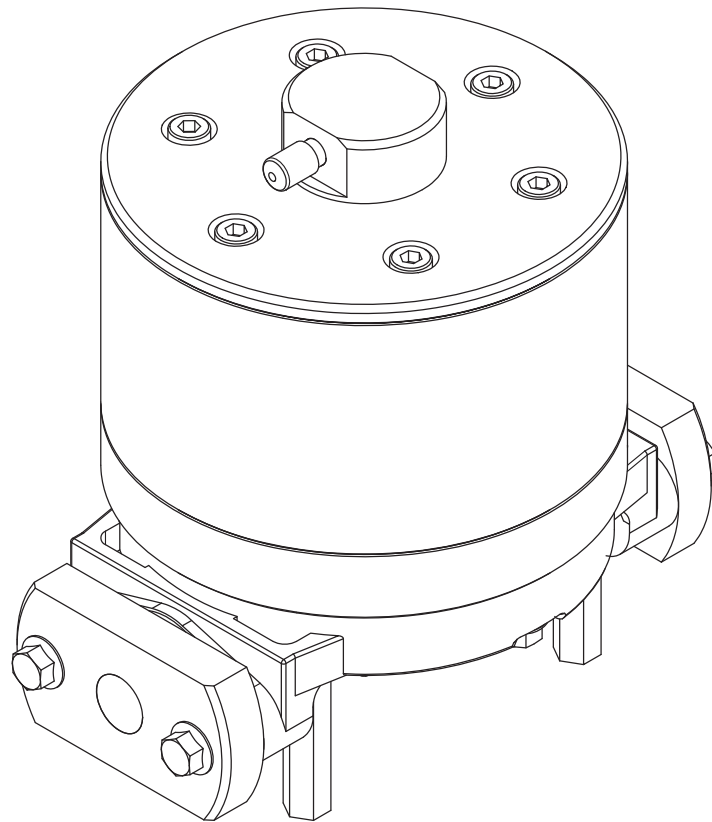

DAMPER SERVICE BOOK



Type 10□ 15□ 25□ 40□ 50□

Series Dampers

HOW TO USE THE DAMPER SERVICE BOOK

Type 40□

- The servicing method for each damper can be different depending on the model and size. Please refer to the "Model Name" noted on the Damper Identification Label and use the below table as a page number and diagram reference guide.

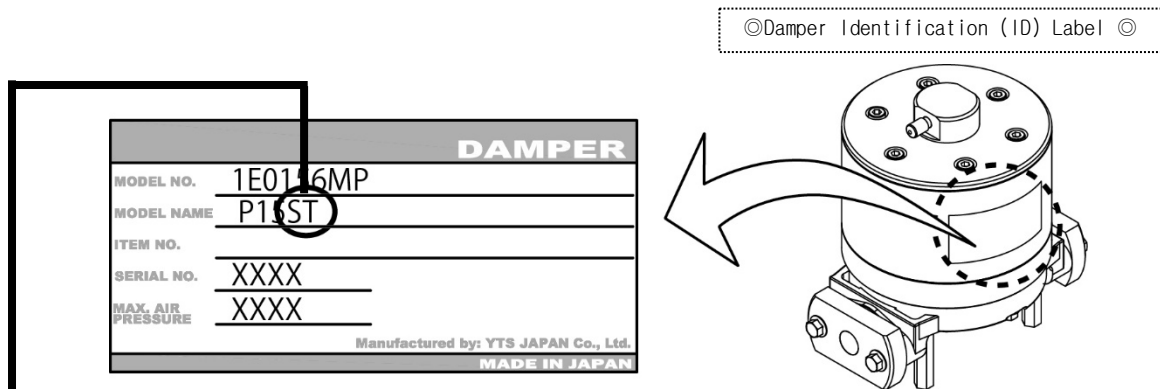

Damper Model Code	· DIAPHRAGM · CENTRE ROD	· CENTRE DISK · DIAPHRAGM · Mounting Direction	· BEARING CENTRE ROD · PILOT VALVE	· Exploded View ※ 1 · Assembly torque values / Re-torque values
Page Number & Diagram Reference Numbers				
AC SC AN SN AE SE AV SV	1-①	2-⑱	3	4-⑦
AH SH AS SS	1-①	2-⑲	3	4-⑦
AT ST	1-①	2-⑳	3	4-⑦
AW SW	1-③	2-㉔	3	4-⑦
GC GE GN GV	1-②	2-㉑	3	4-⑧
GH GS VS	1-②	2-㉒	3	4-⑧
GT VT	1-②	2-㉓	3	4-⑧
GW VW	1-④	2-㉔	3	4-⑧

※ 1) Before operating the damper for the first time please re-torque all bolts. Also re-torque bolts if leaks are discovered as part of the daily inspection regime.

Description of Diagrams used within the Damper Service Book

	Check Condition & Measurements Carefully		Use Oil to help with Assembly		Use Grease to help with Assembly		Apply LOCTITE® to adhere
	If within tolerance then continue to Use		If beyond allowable tolerance then dispose		Replace with New Parts		Hand-tight

⚠ **WARNING**



For your own safety and the safety of the people around you, be sure to read the procedures noted within carefully before performing maintenance on this product. After reading this document, be sure to keep it handy for future reference.

⚠ **WARNING**



Before commencing any maintenance work, Disconnect the compressed air supply and remove and clean any remaining liquids contained on around or within the damper. If liquids are not removed or neutralized then there is a possibility of a serious injury such as burns, blindness, poisoning or even death if chemicals adhere to the skin eyes or are accidentally inhaled or swallowed. If residual air pressure is present within the damper there could be a danger of sudden decompression or explosion resulting in severe injury or even death. In case of disassembling, be sure to wear protective equipment, such as face mask, gloves, etc. When replacing spare parts, be sure to use genuine YTS parts. The installation and use of non-specified parts may cause a malfunction or damage to the product.

Service Tools

Ⓐ Sleeve Puller Tool (Can be purchased separately)

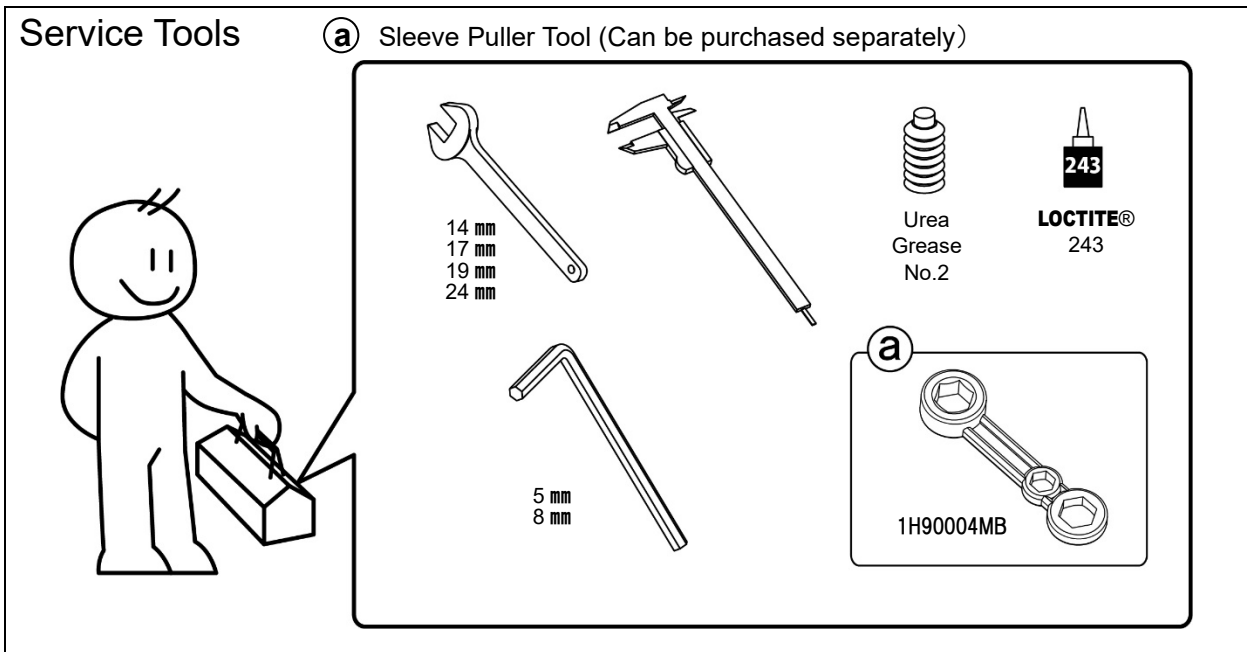

Recommended Changeover Time for the Replacement of Diaphragms ※

CR, NBR, EPDM	10 million cycles
FKM	2.5 million cycles
PTFE	3 million cycles
TPEE, TPO	15 million cycles
PTFE·EPDM	20 million cycles

- ※ Conditions; with fresh water at room temperature and 0 head
Conditions such as over pressurization, dry running high or low temperatures, Chemical attack or Abrasion etc. can drastically shorten diaphragm life.
- ※ O-rings and packing should be replaced during service.
- ※ When reassembling the damper please follow the disassembly Procedure in reverse. For all torque values refer to the Exploded view on page 4.
- ※ When ordering spare parts, please refer to the damper "SERIAL NO.". As stated on the Identification label.

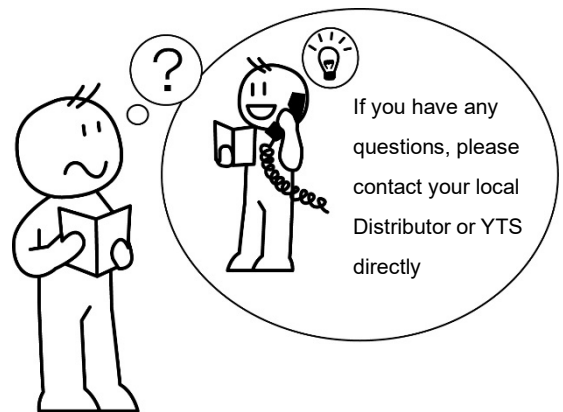

Retightening

1. Before starting operation.
2. At quarterly inspections after installation. (Biannual if the room temperature, such as in a clean room, is maintained within plus or minus 5°C of the ambient temperature.)
3. When restarting the pump with low temperature after it stops running because ambient temperature or liquid temperature becomes too high, and low while it stops.
4. If you find fluid leakage on daily inspection.

1

10A□ 10S□ 15A□ 15S□

25A□ 25S□

1-①

40A□ 40S□

50A□ 50S□

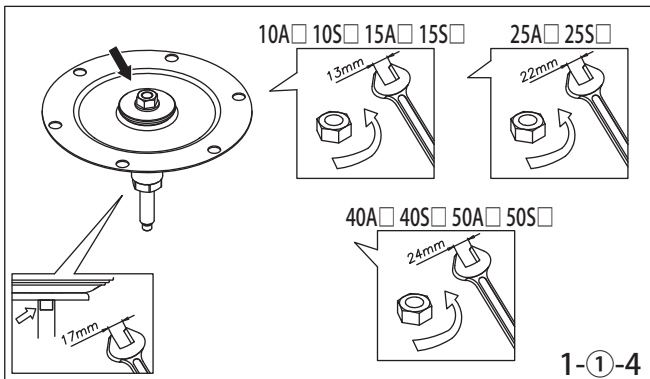
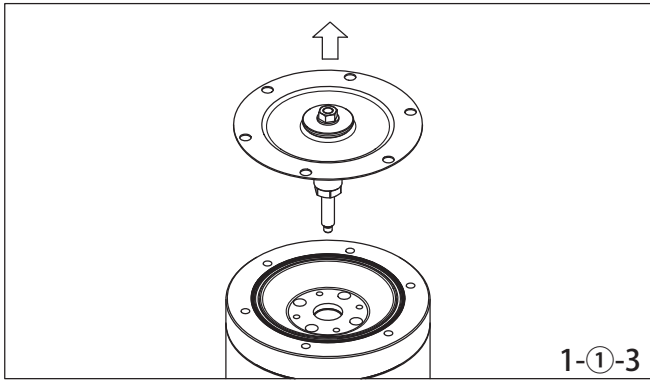
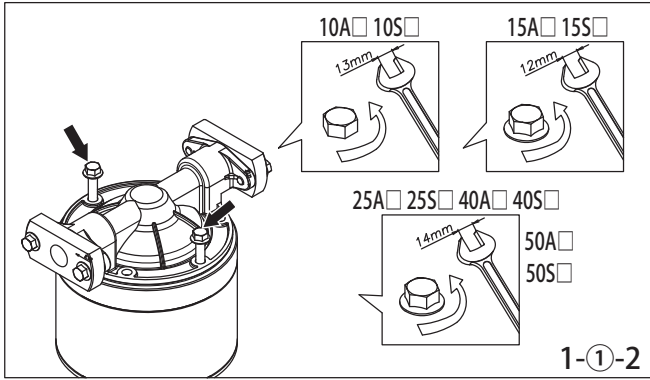
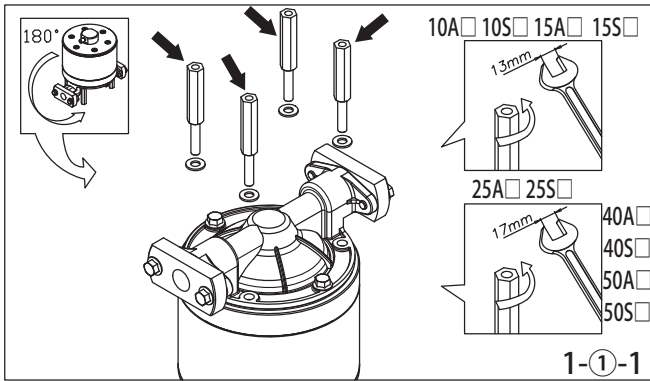

10P□ 15P□ 15V□

25G□ 25V□

1-②

40G□ 40V□

50G□ 50V□

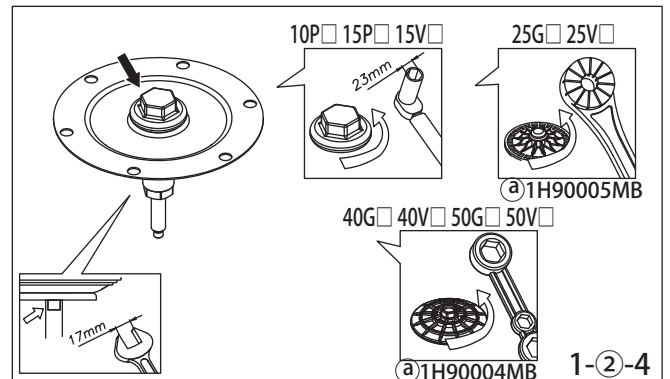
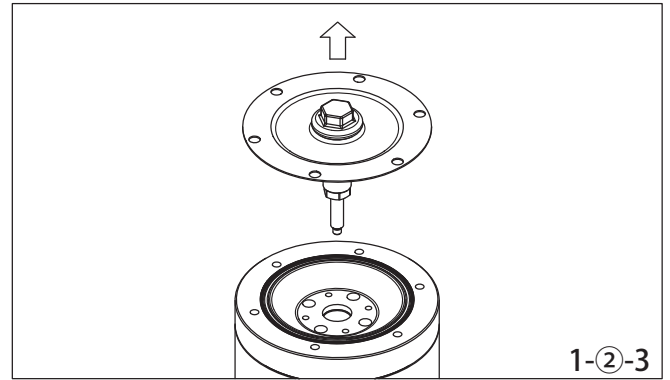
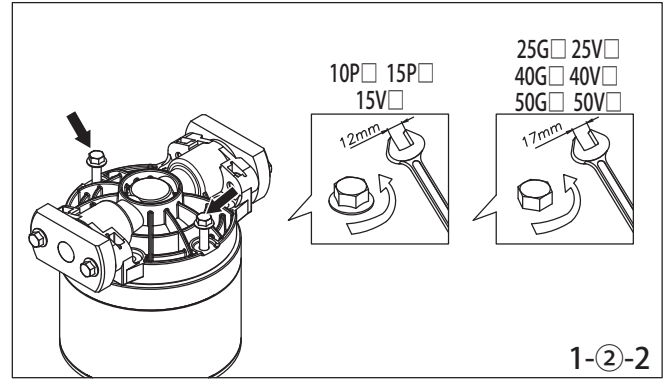
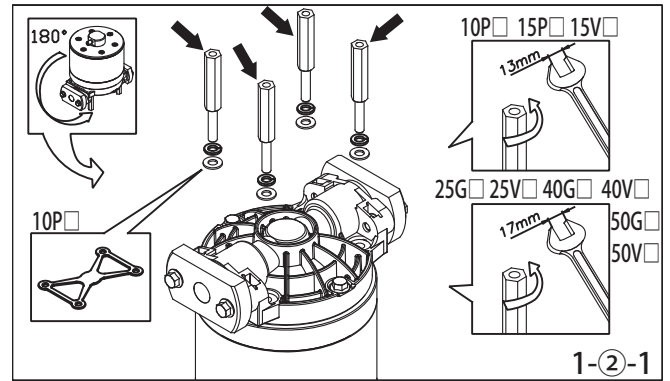

1

10AW 10SW 15AW 15SW
25AW 25SW
1-③ 40AW 40SW
50AW 50SW

10PW 15PW 15VW
25GW 25VW
1-④ 40GW 40VW
50GW 50VW

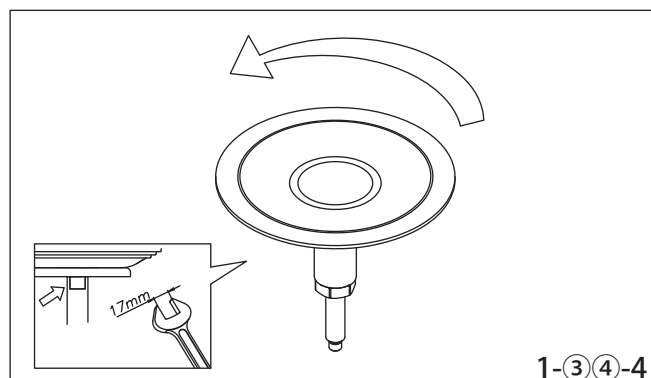
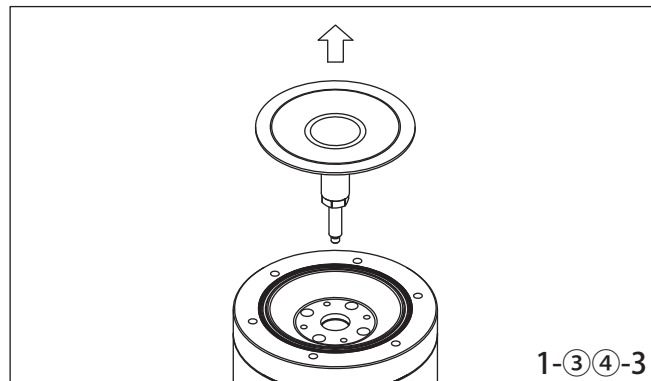
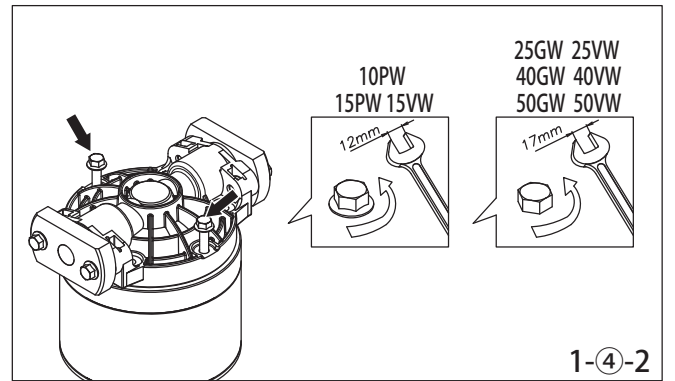
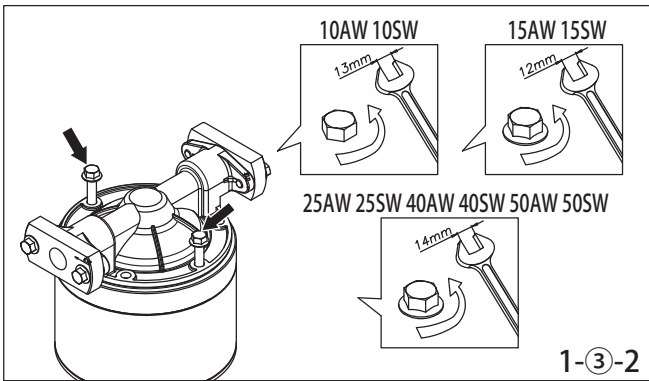
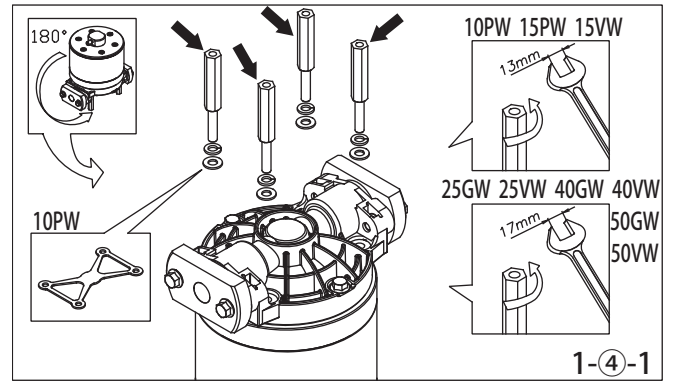
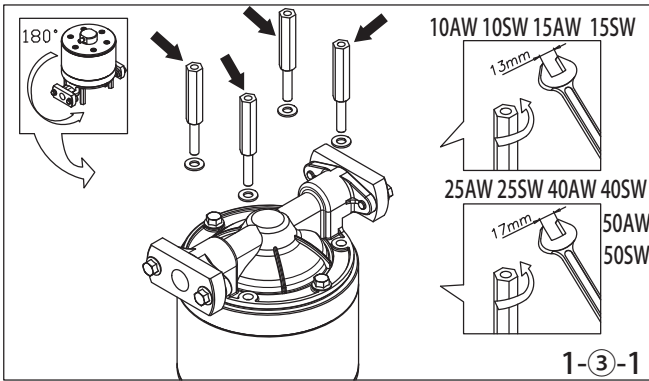

2

2-① 10AH 10SH
10AS 10SS

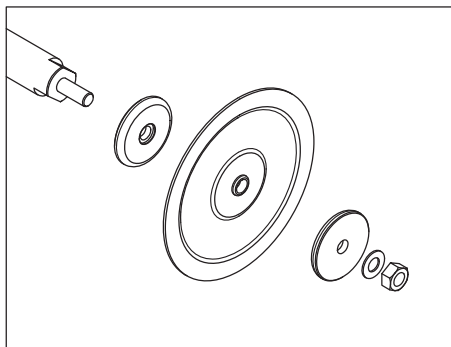

2-② 10AC 10SC
10AN 10SN
10AT 10ST

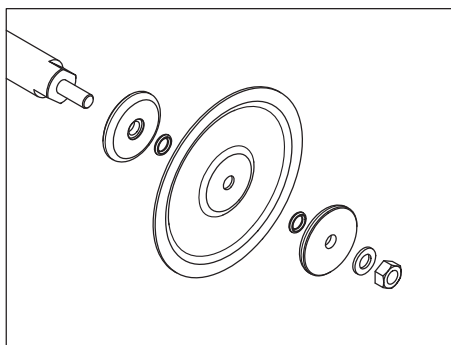

2-③ 10PH
10PS

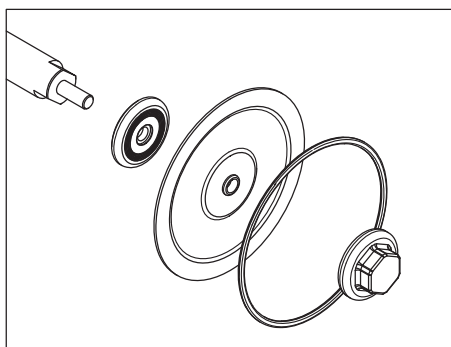

2-④ 10PC
10PN
10PT

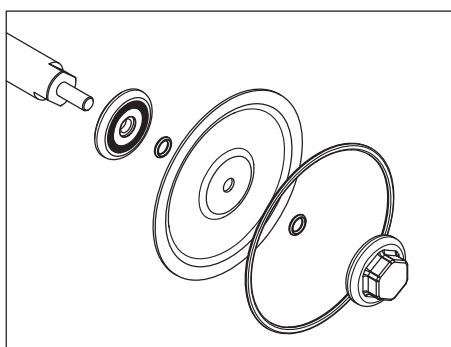

2-⑤ 10AW 10SW
10PW

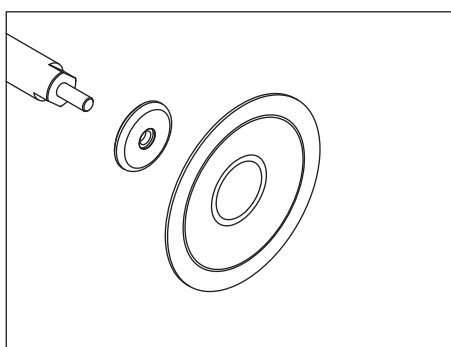

2

2-⑥ 15AC 15SC
15AN 15AN
15AH 15SH
15AS 15SS

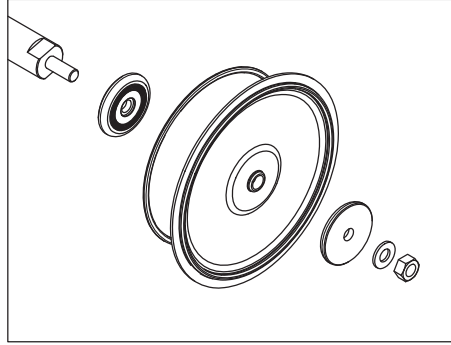

2-⑦ 15AT 15ST

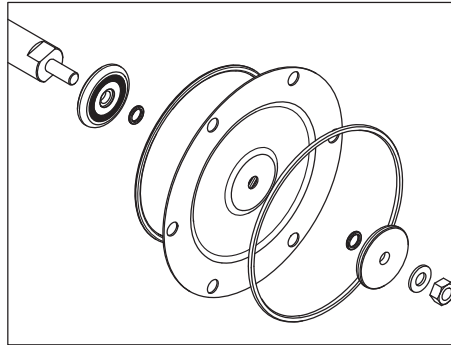

2-⑧ 15PC 15VS
15PN
15PH
15PS

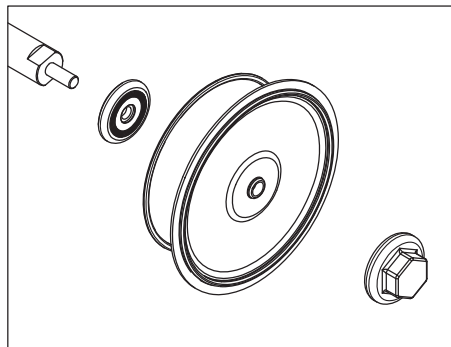

2-⑨ 15PT 15VT

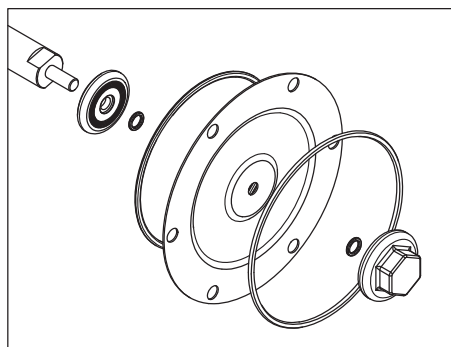

2-⑩ 15AW 15SW
15PW 15VW

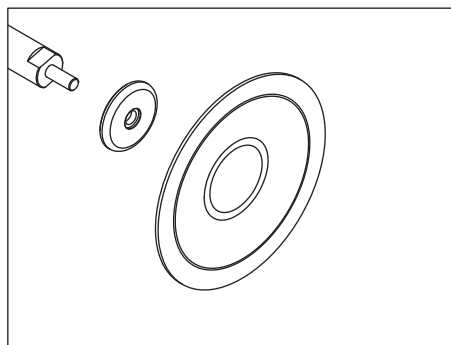

2

2-⑪ 25AC 25SC
25AN 25SN
25AE 25SE
25AV 25SV

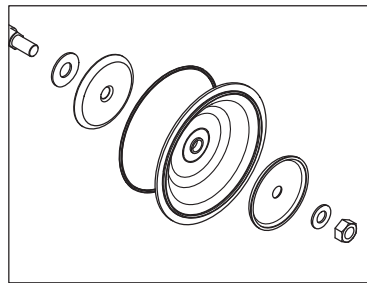

2-⑫ 25AH 25SH
25AS 25SS

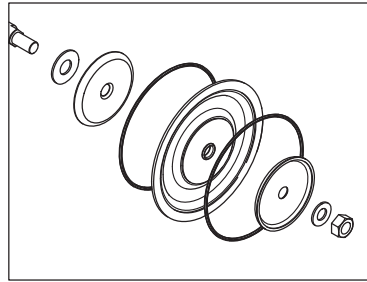

2-⑬ 25AT 25ST

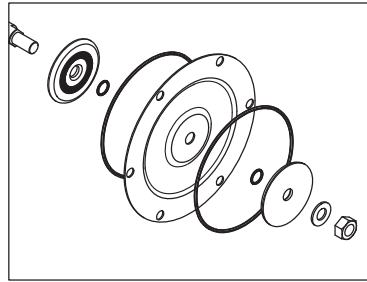

2-⑭ 25GC
25GN
25GE
25GV

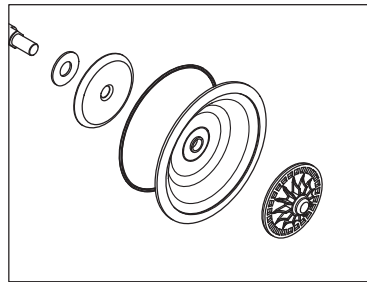

2-⑮ 25GH 25VS
25GS

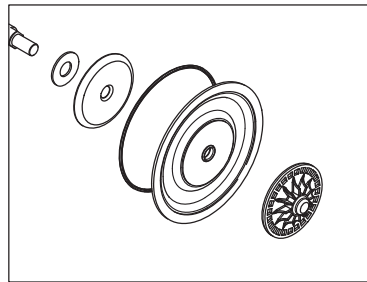

2-⑯ 25GT 25VT

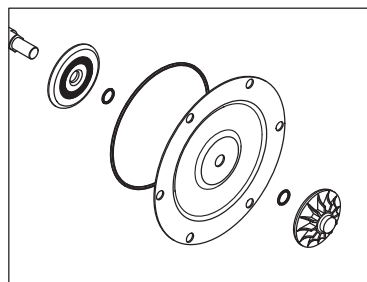

2-⑰ 25AW 25SW
25GW 25VW

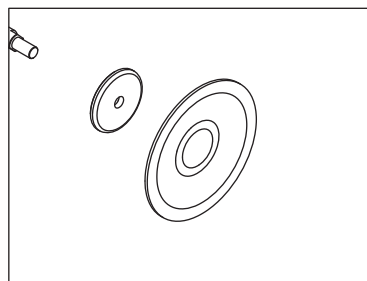

2

2-18 40AC 40SC
40AN 40SN
40AE 40SE
40AV 40SV

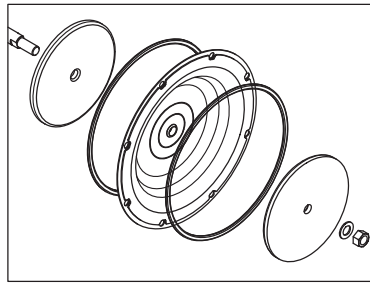

2-19 40AH 40SH
40AS 40SS

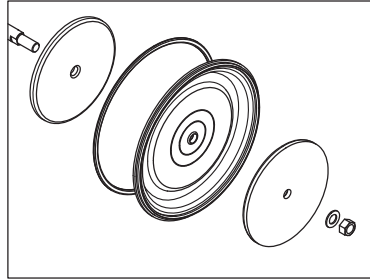

2-20 40AT 40ST

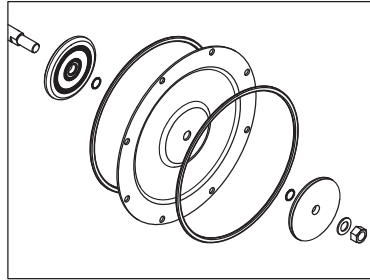

2-21 40GC
40GN
40GE
40GV

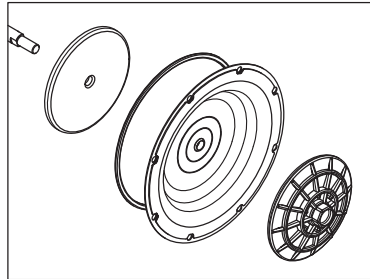

2-22 40GH 40VS
40GS

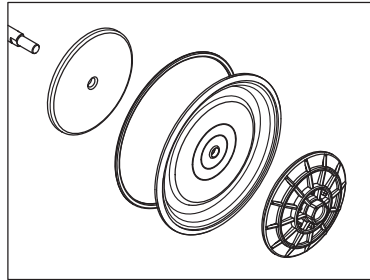

2-23 40GT 40VT

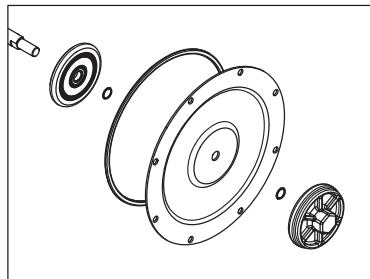

2-24 40AW 40SW
40GW 40VW

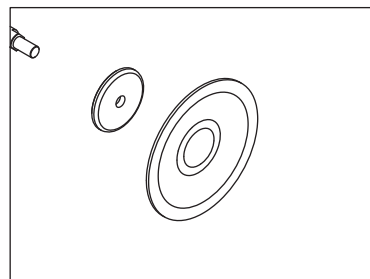

2

2-(25) 50AC 50SC
50AN 50SN
50AE 50SE
50AV 50SV

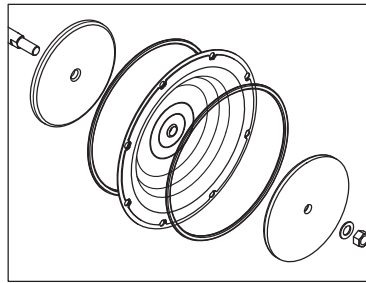

2-(26) 50AH 50SH
50AS 50SS

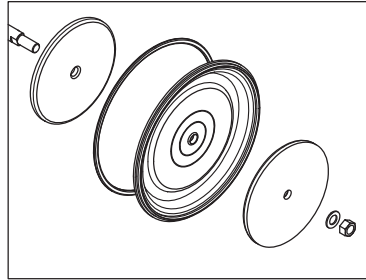

2-(27) 50AT 50ST

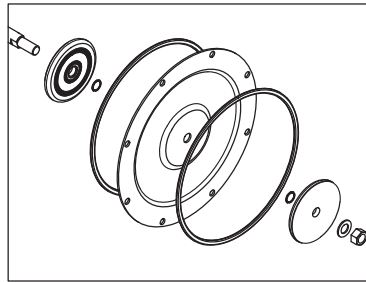

2-(28) 50GC
50GN
50GE
50GV

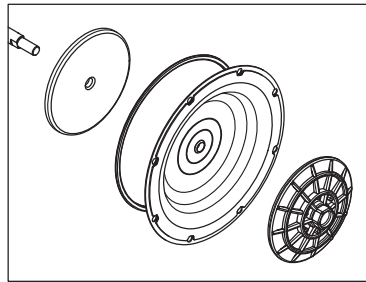

2-(29) 50GH 50VS
50GS

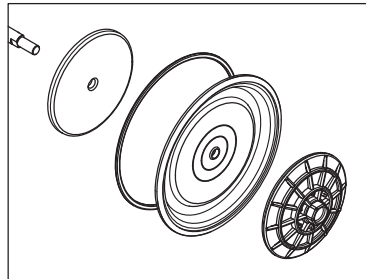

2-(30) 50GT 50VT

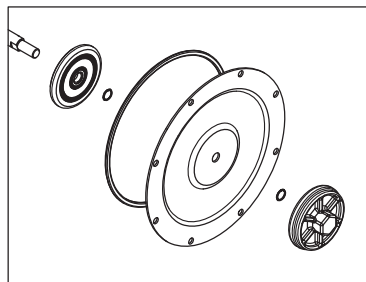

2-(31) 50AW 50SW
50GW 50VW

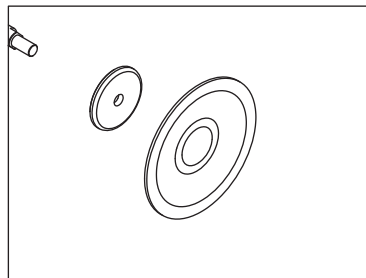

2

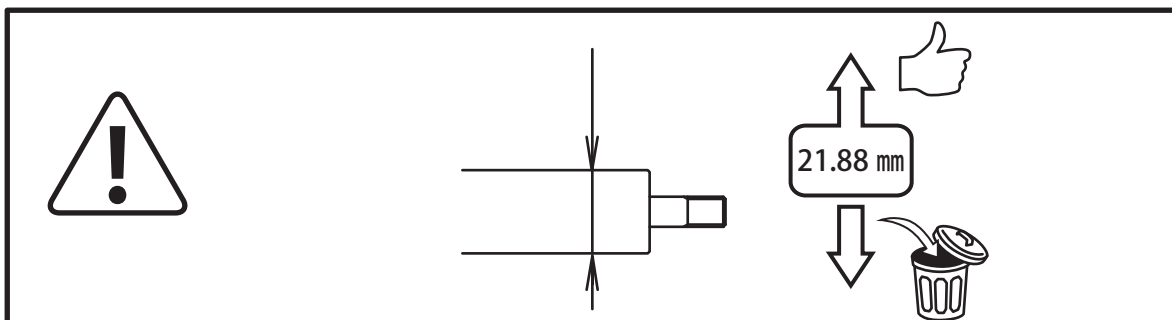
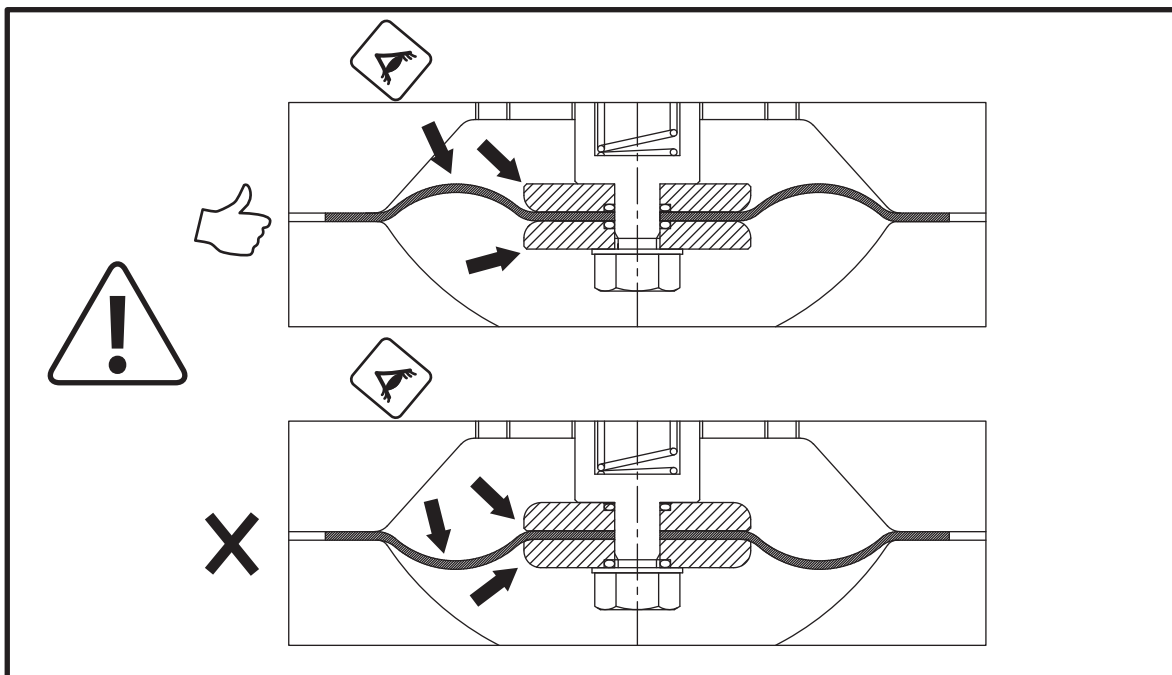

2-⑤ 2-⑩ 2-⑰ 2-⑳ 2-㉑

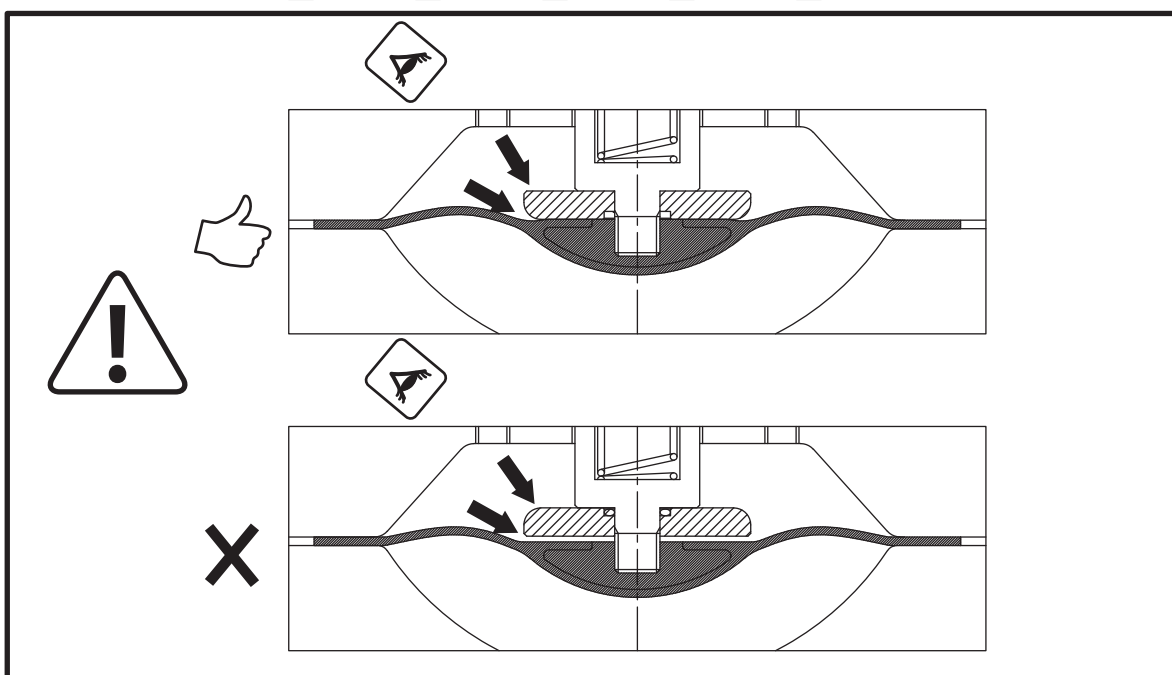

3

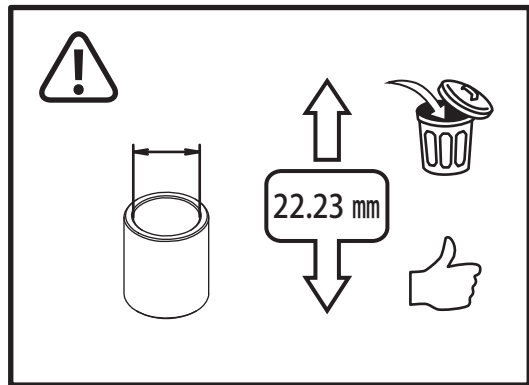
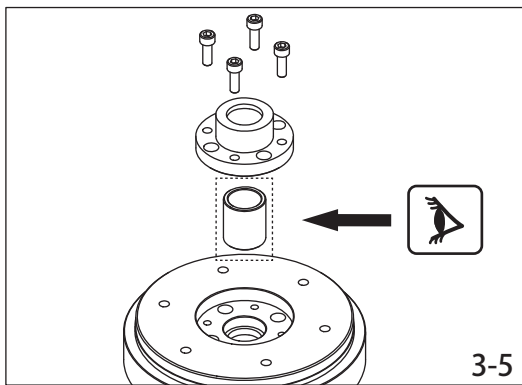
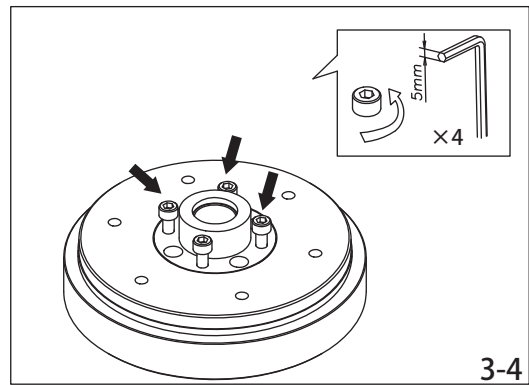
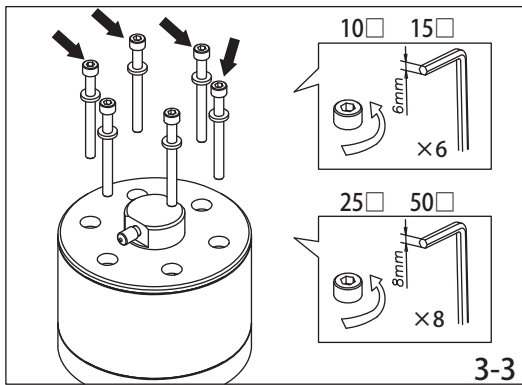
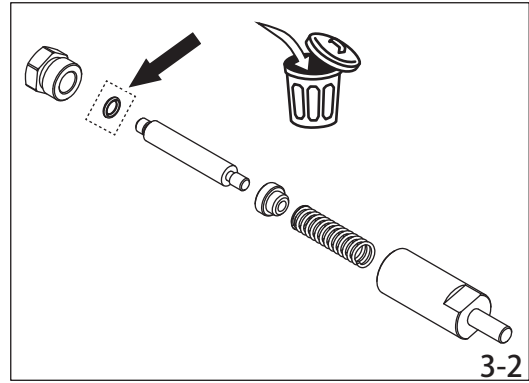
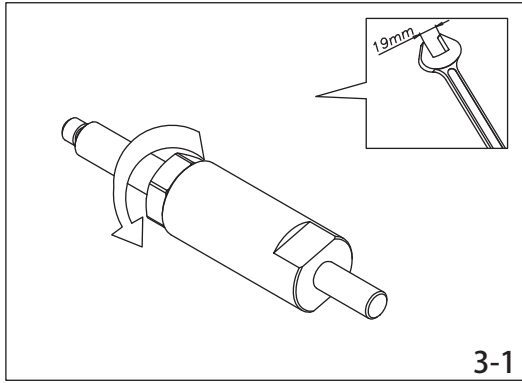

4 10A □ 10S □

4-①

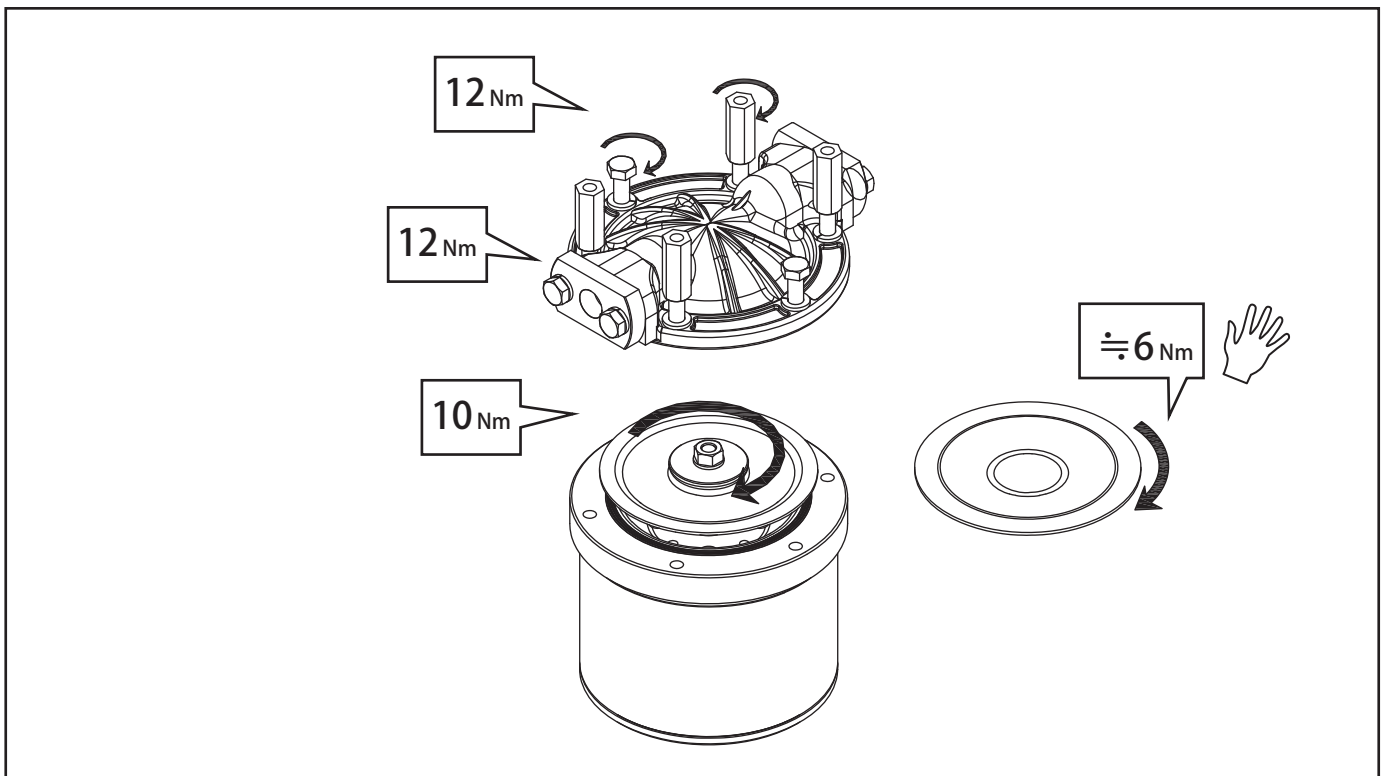
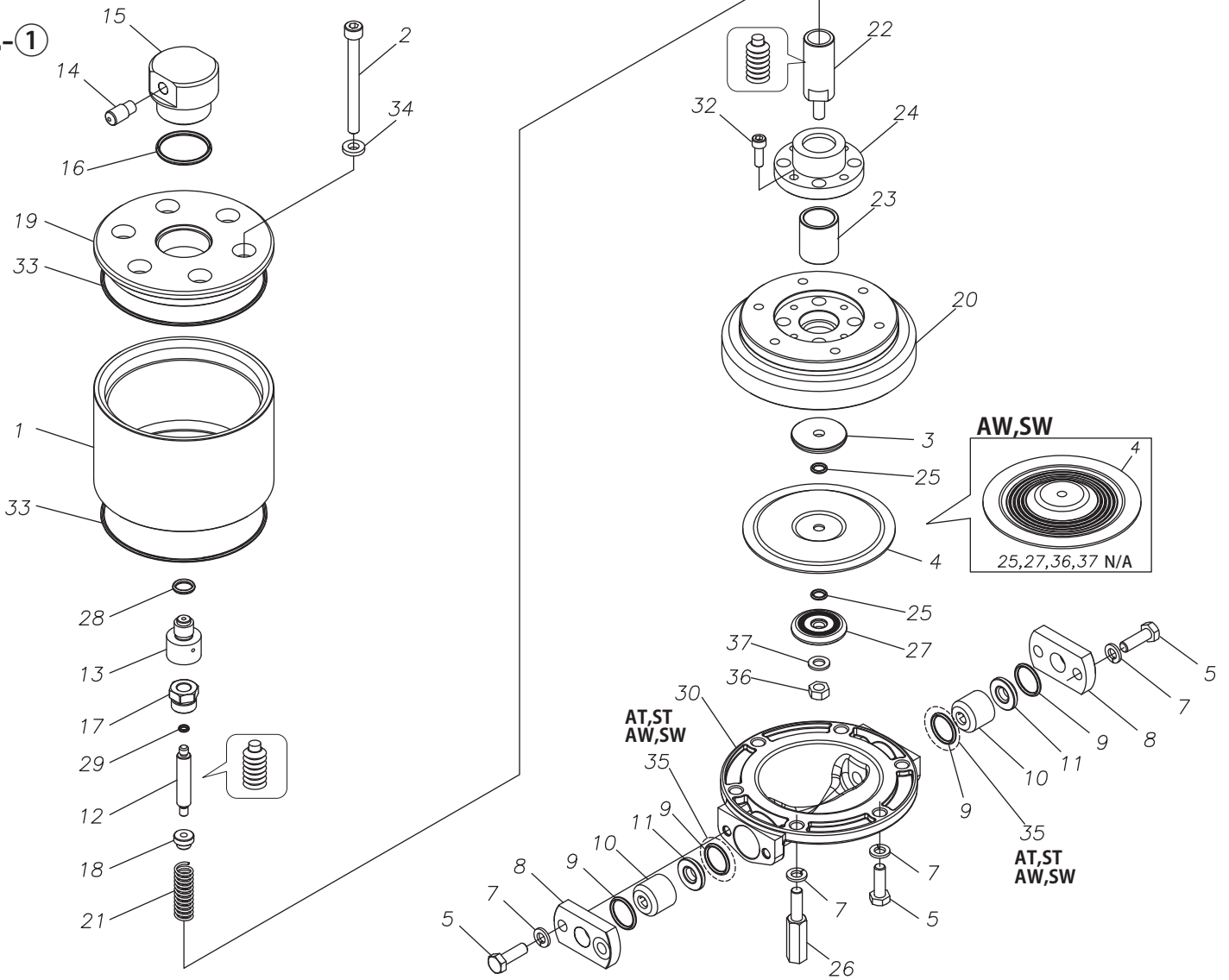

4

10P□

4-②

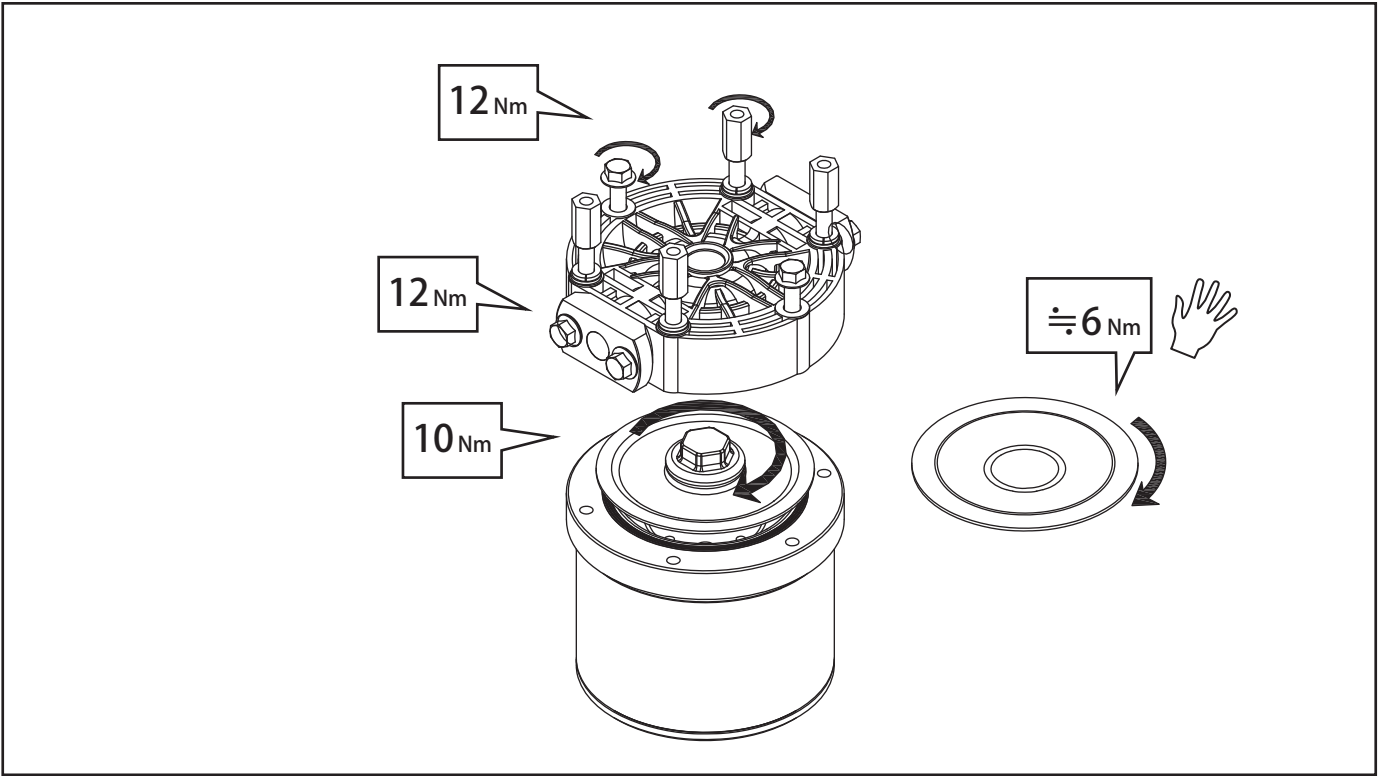
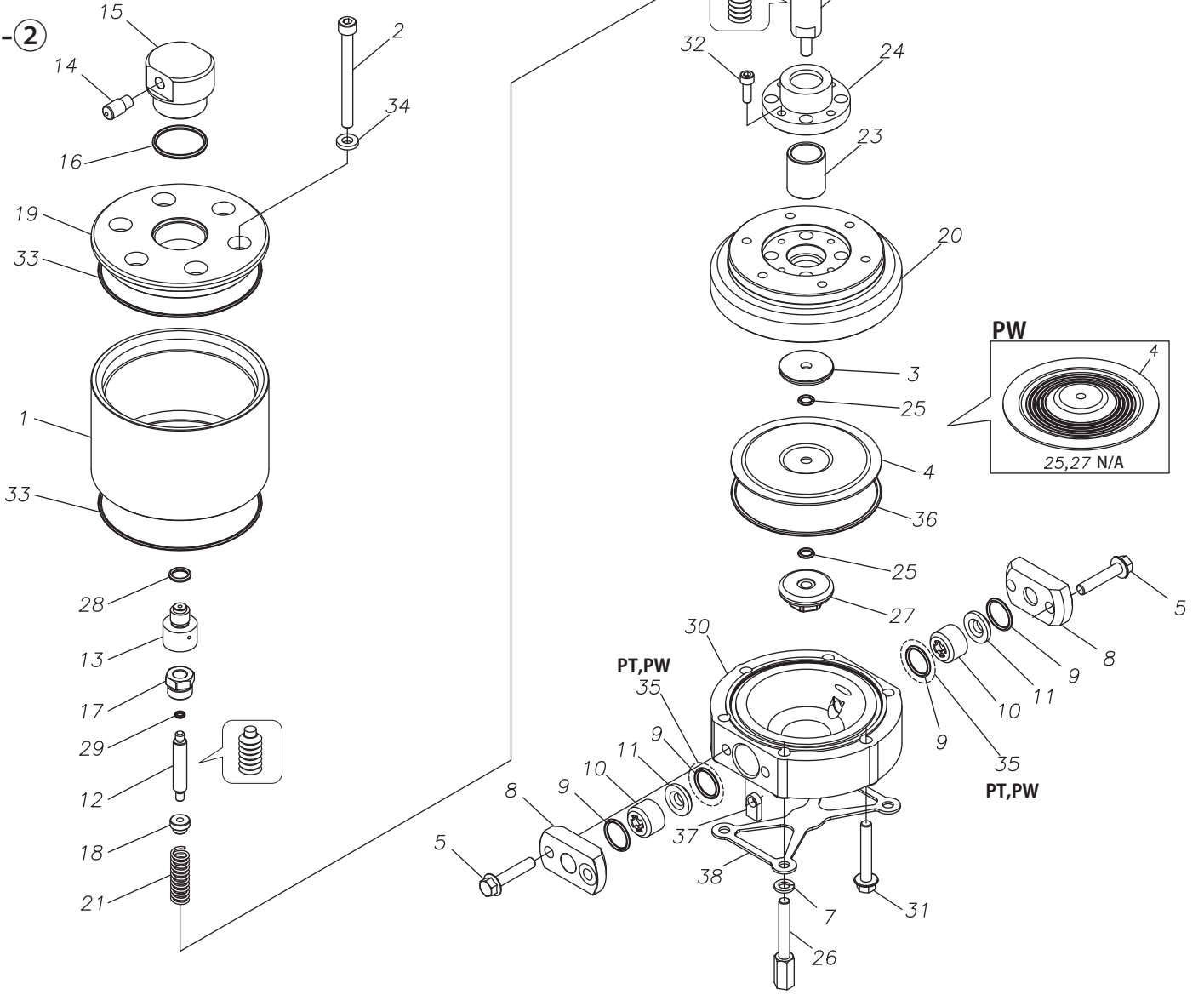

4 15A □ 15S □

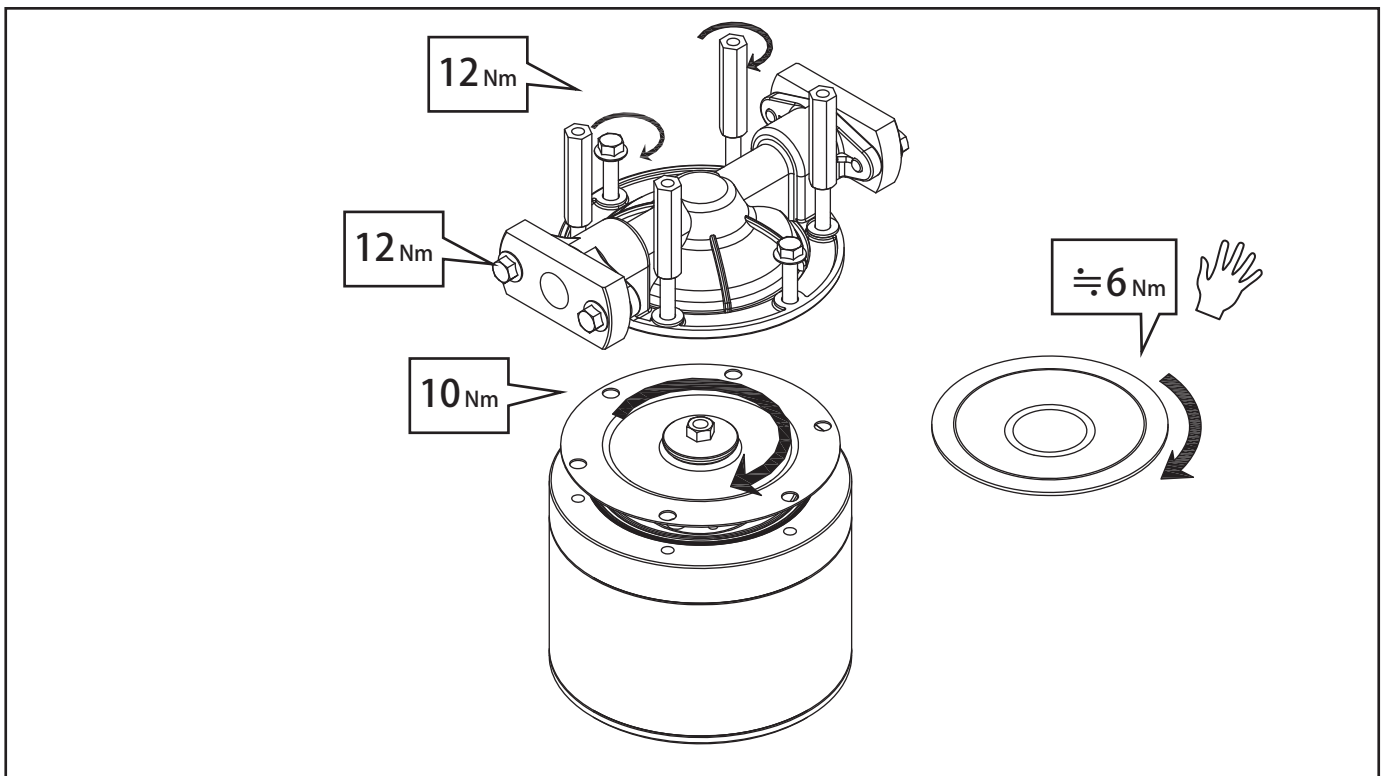
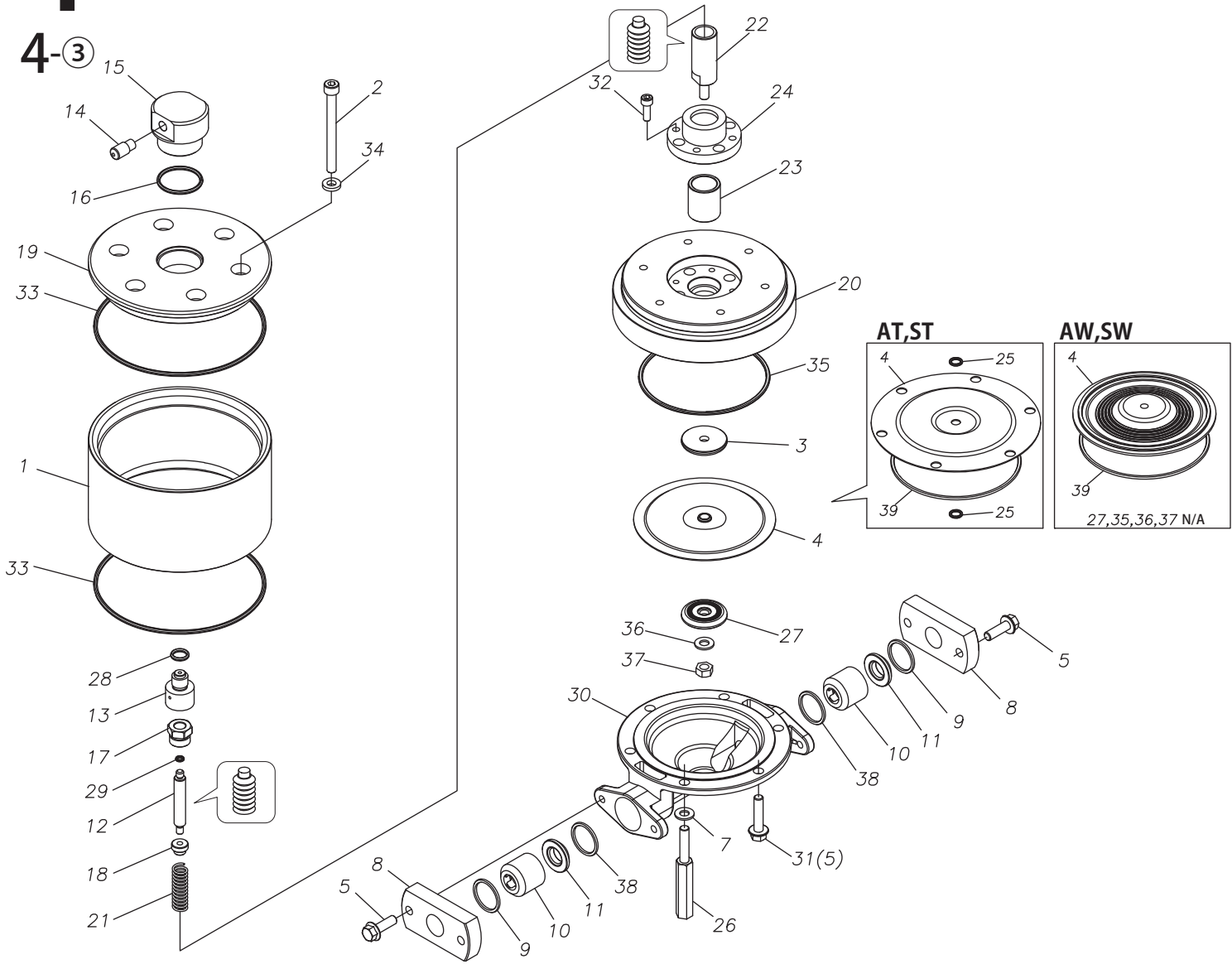

4 15P□ 15V□

4-4

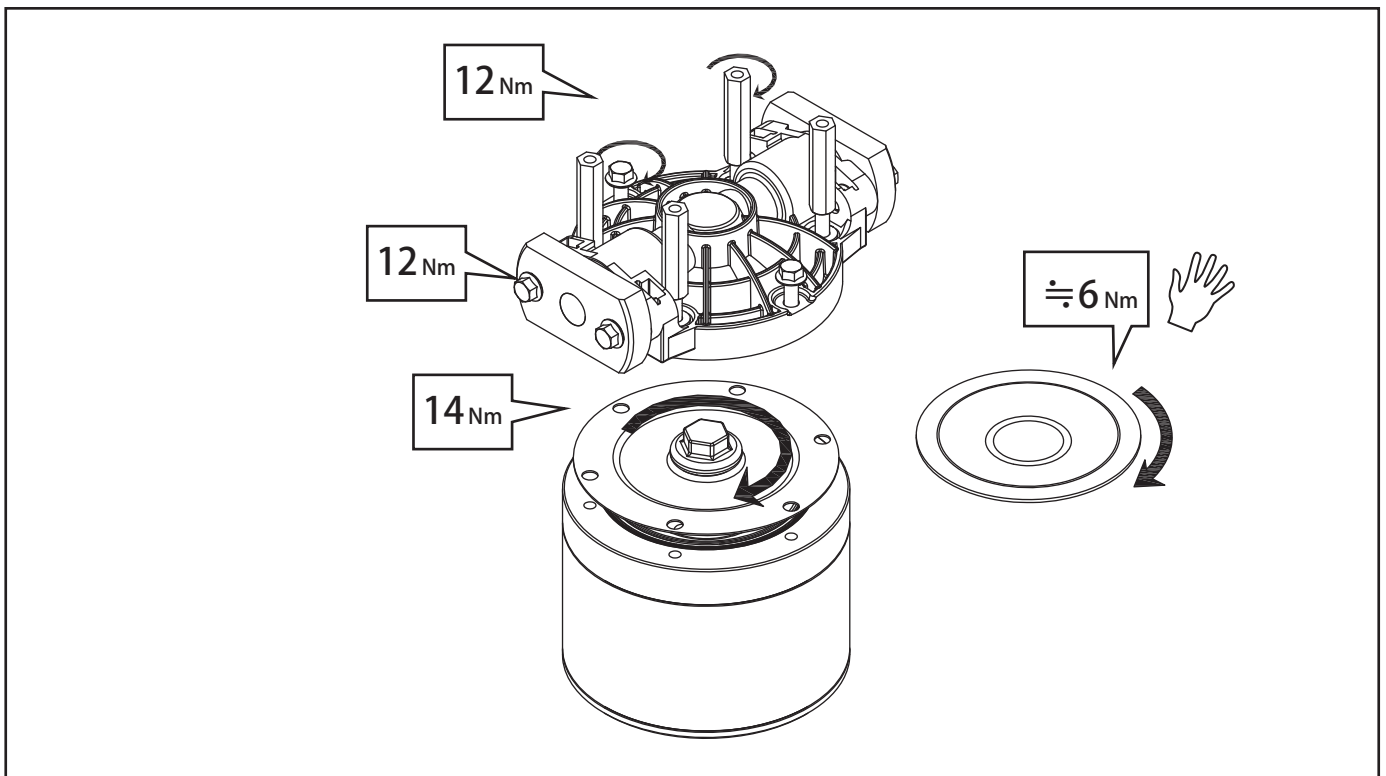
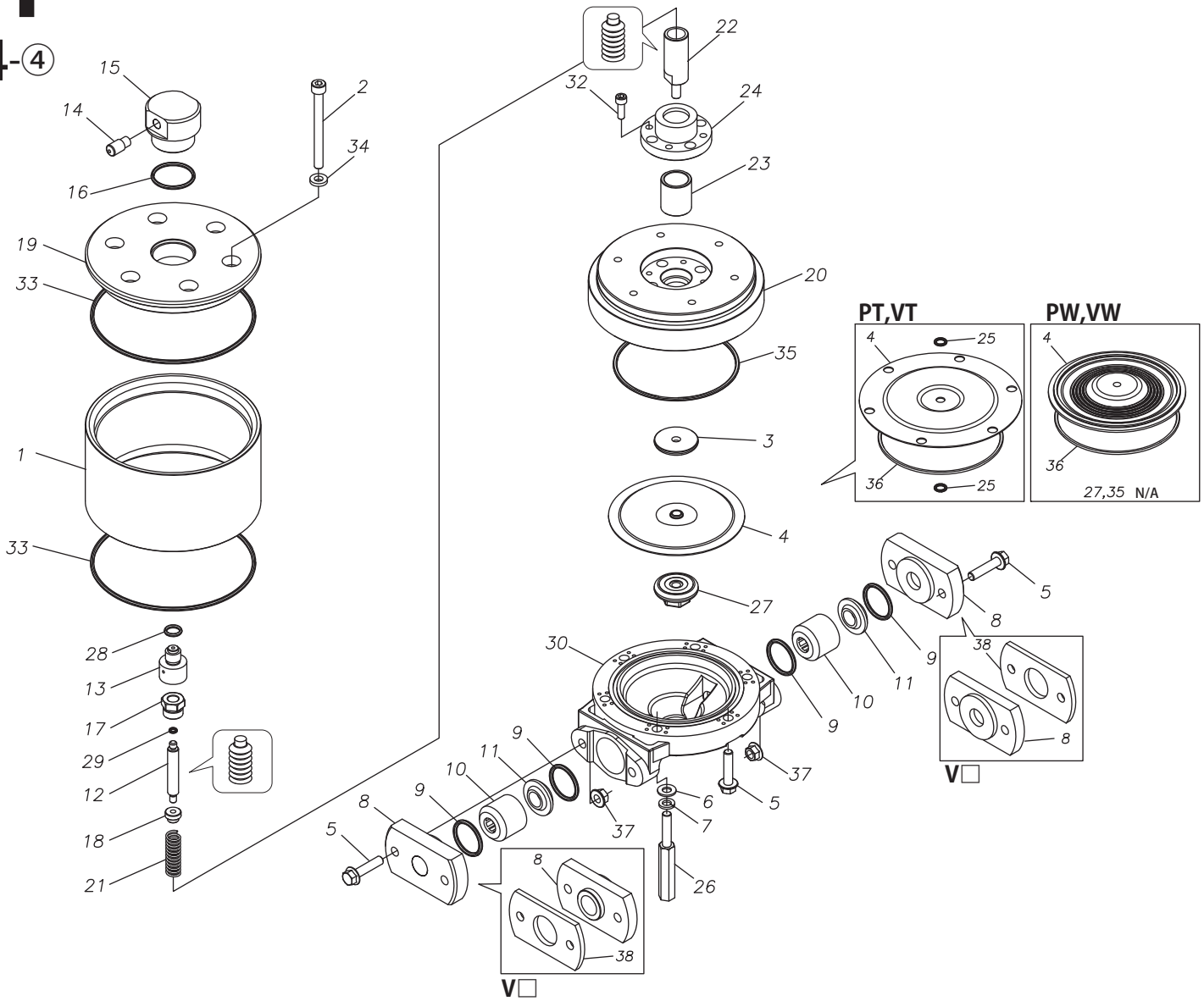

4 25A □ 25S □

4-5

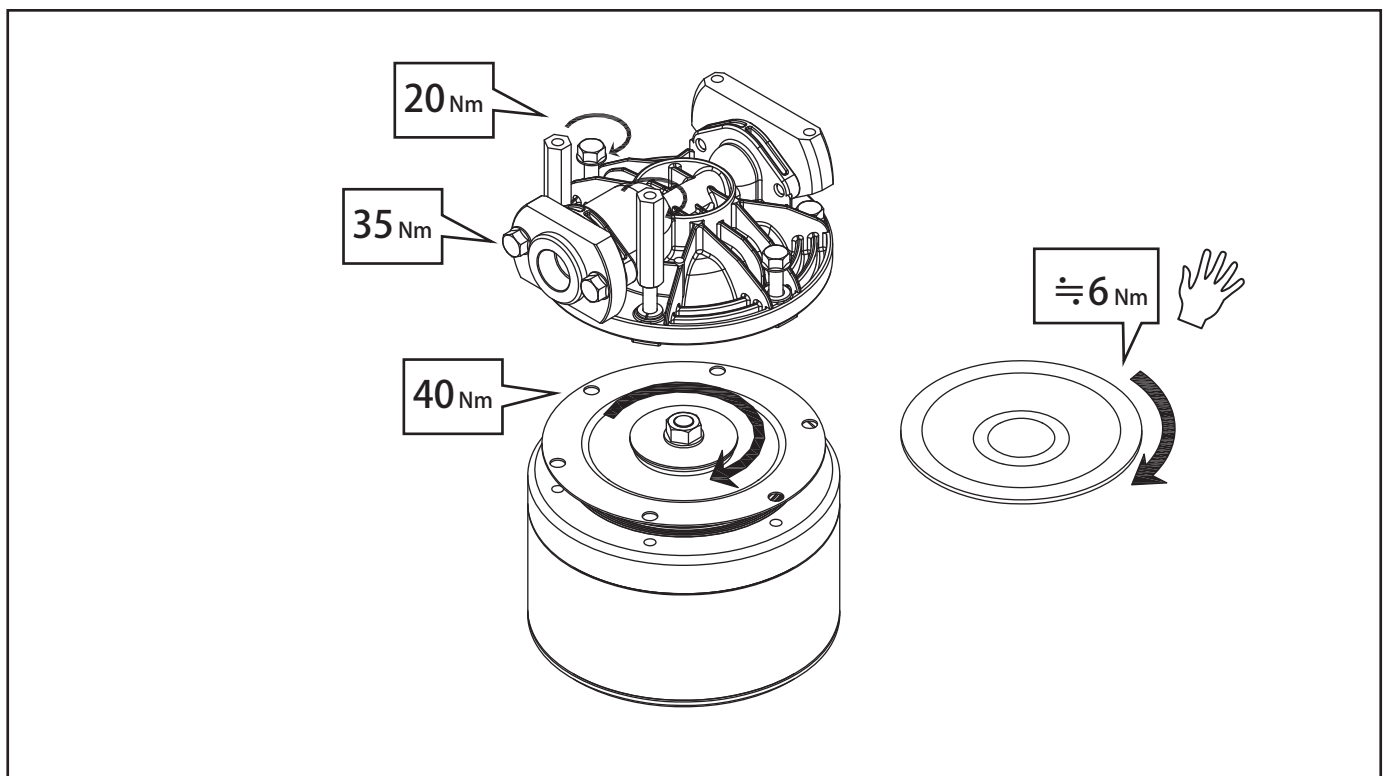
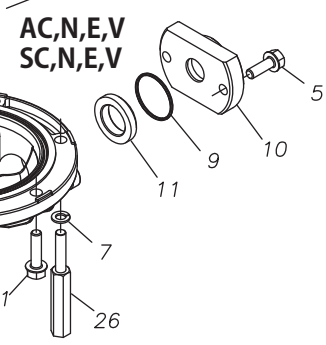
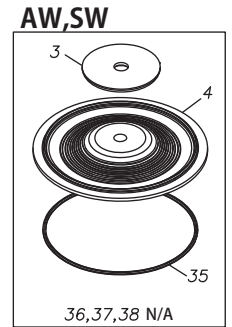
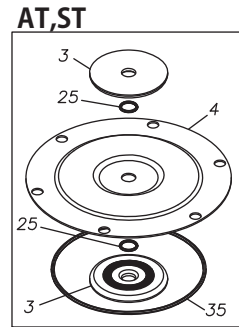
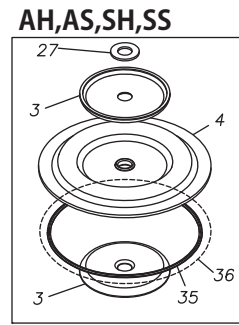
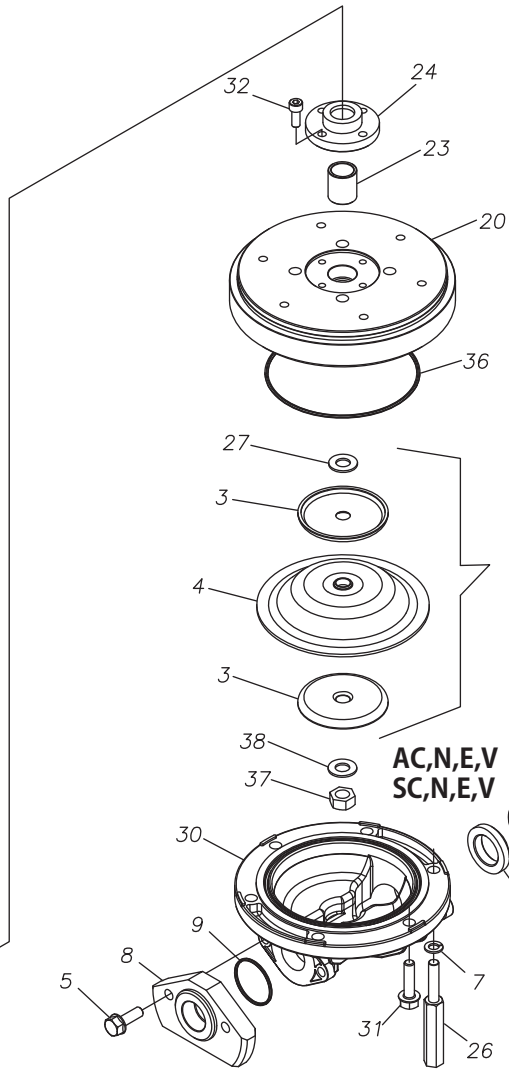
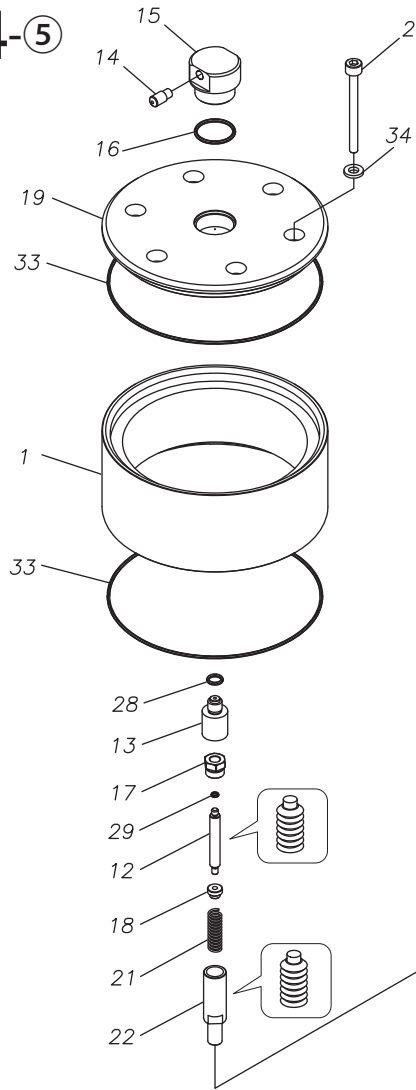

4 25G□ 25V□

4-⑥

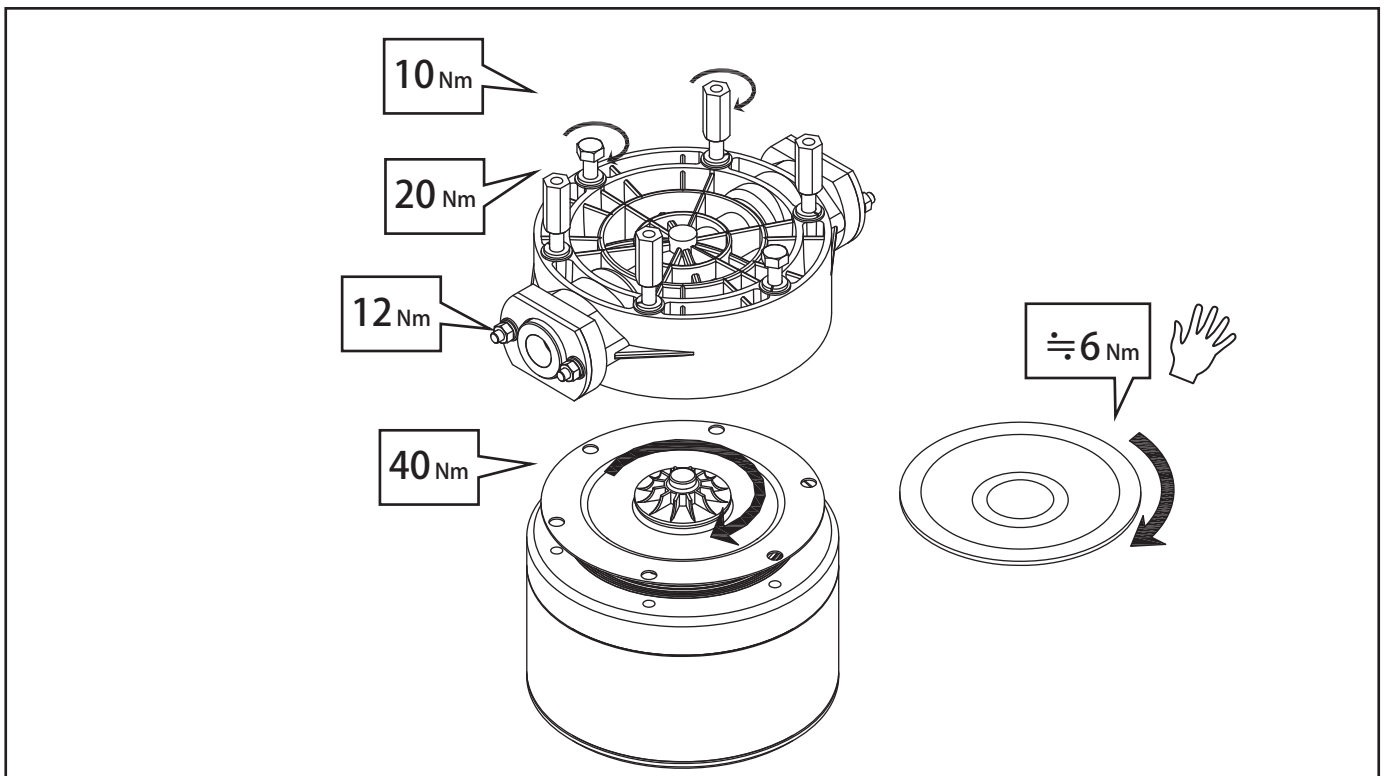
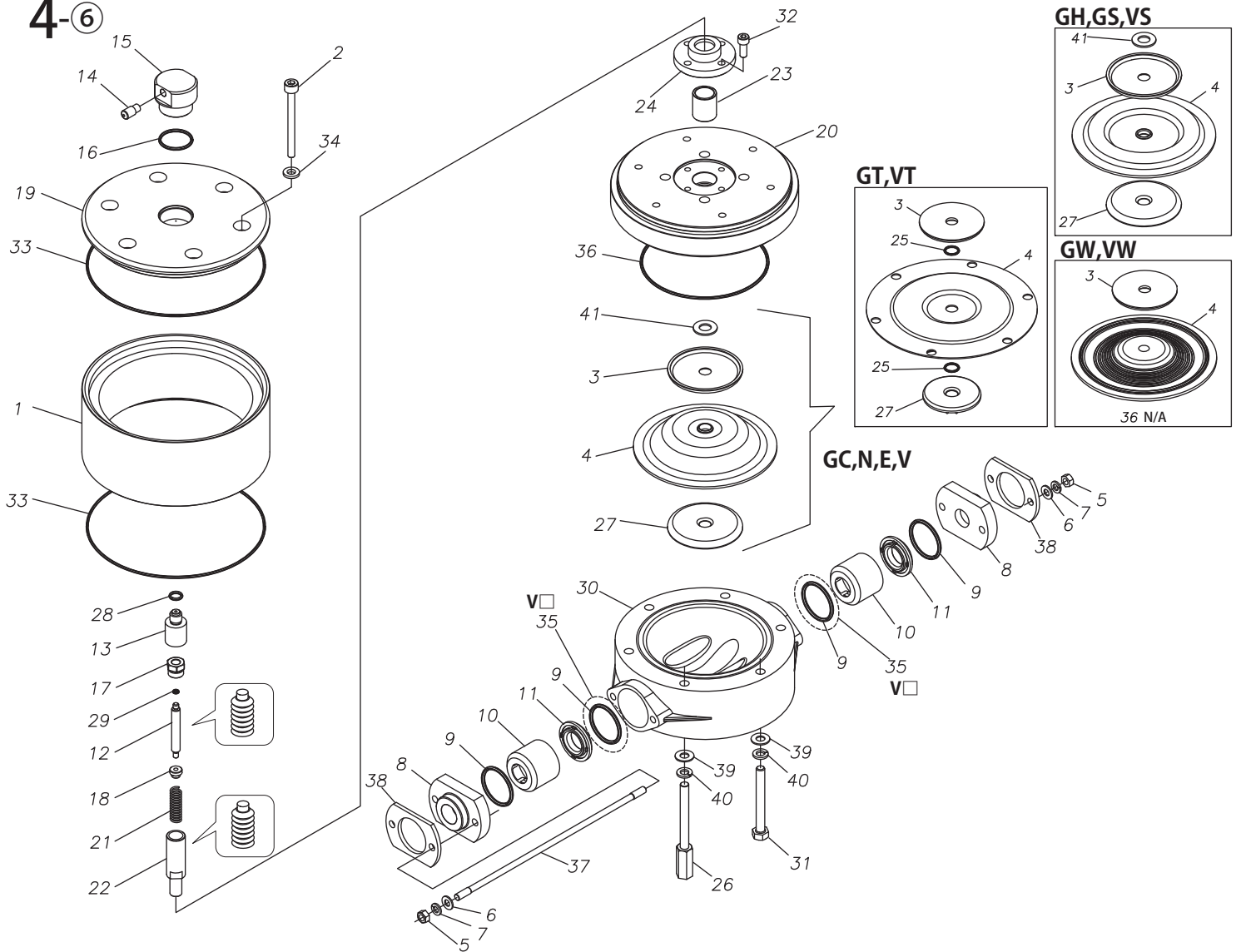

4

40A □ 40S □

4-7

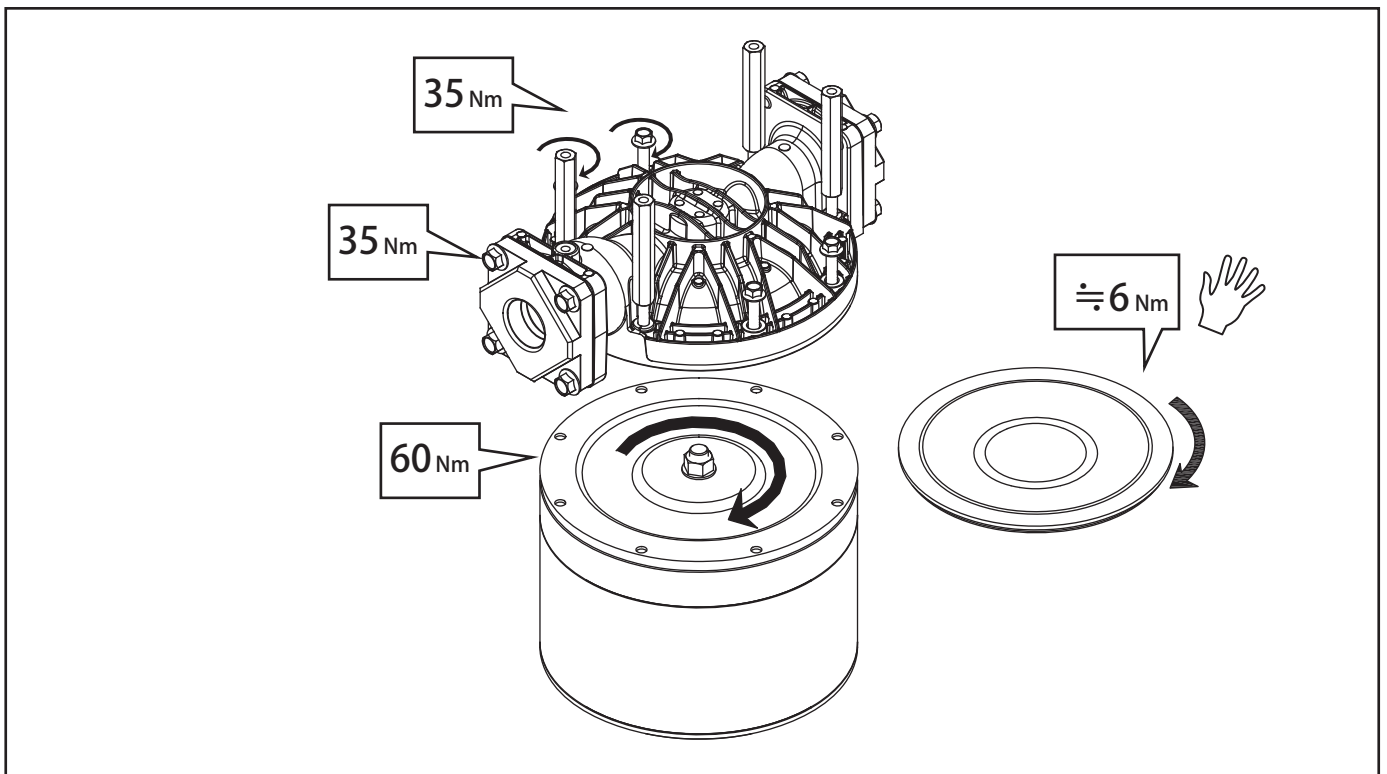
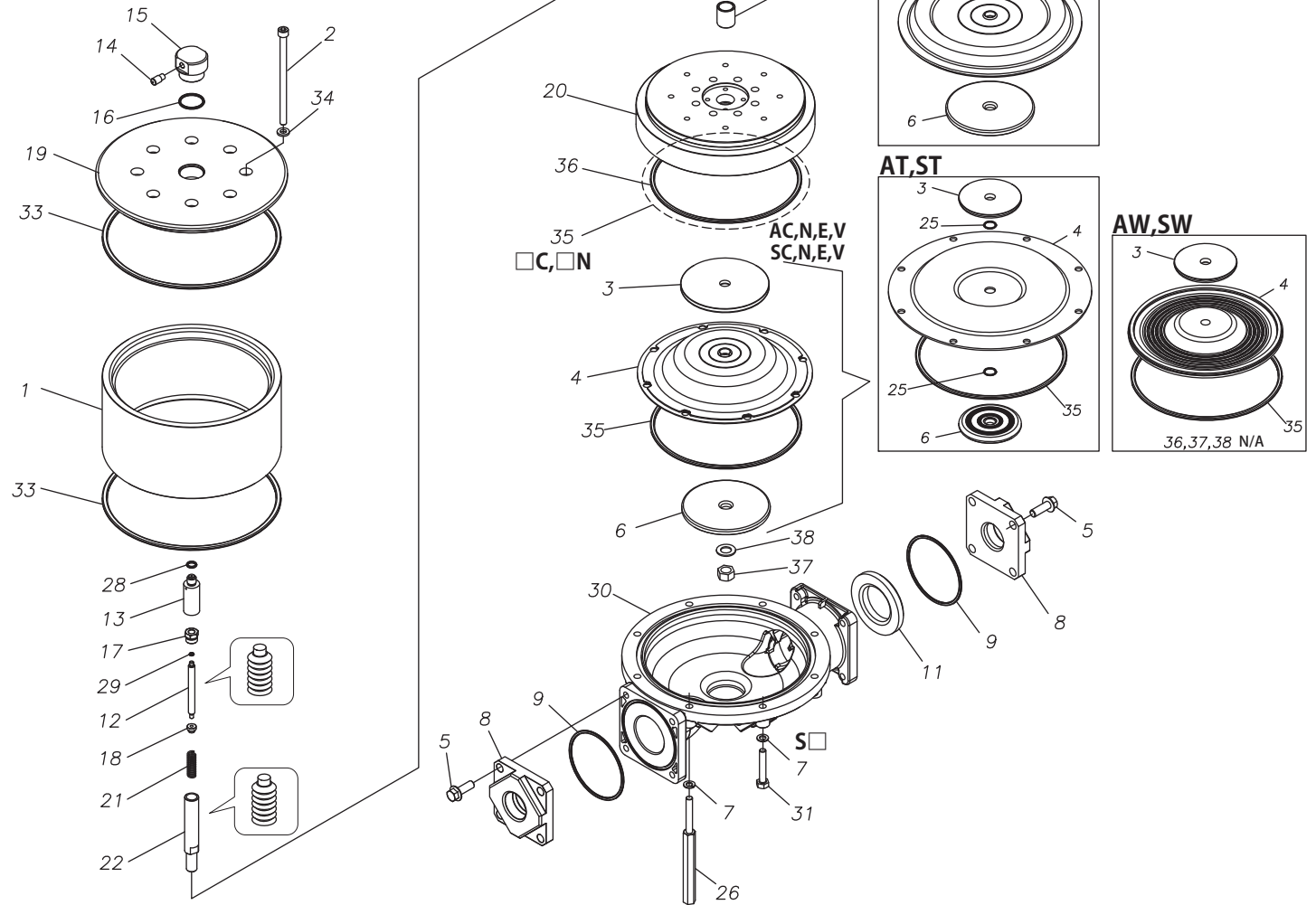

4

 40G□ 40V□

4-⑧

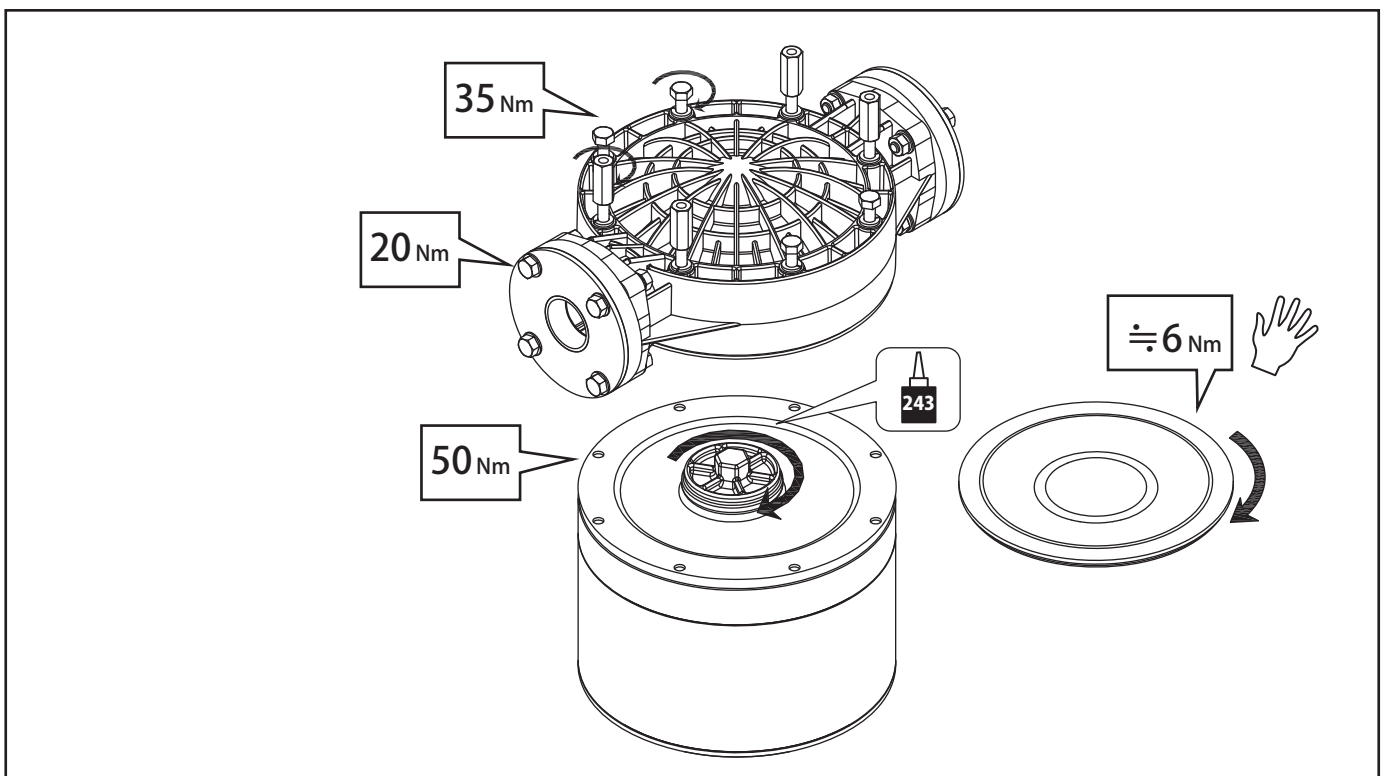
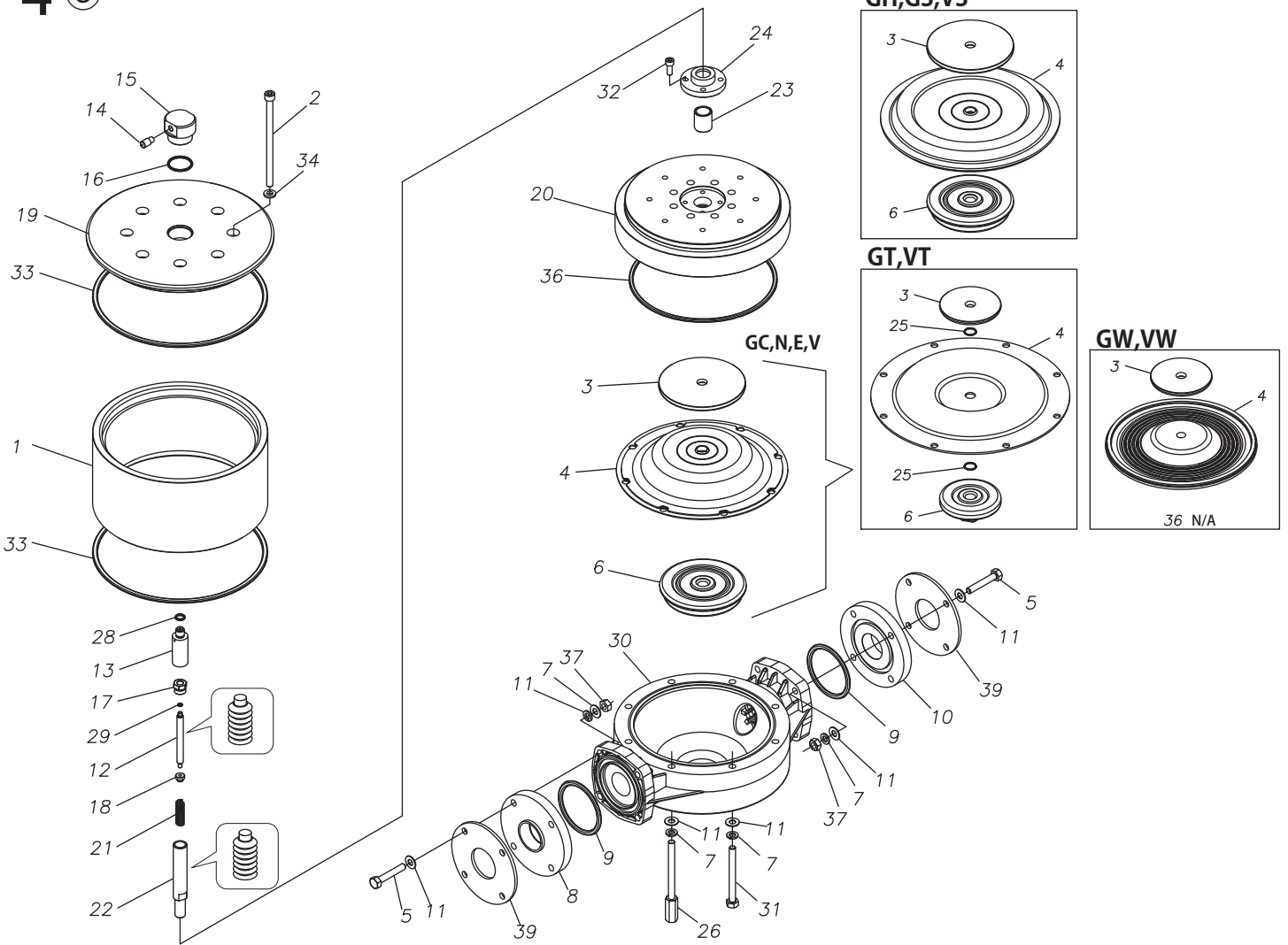

4 50A □ 50S □

4-9

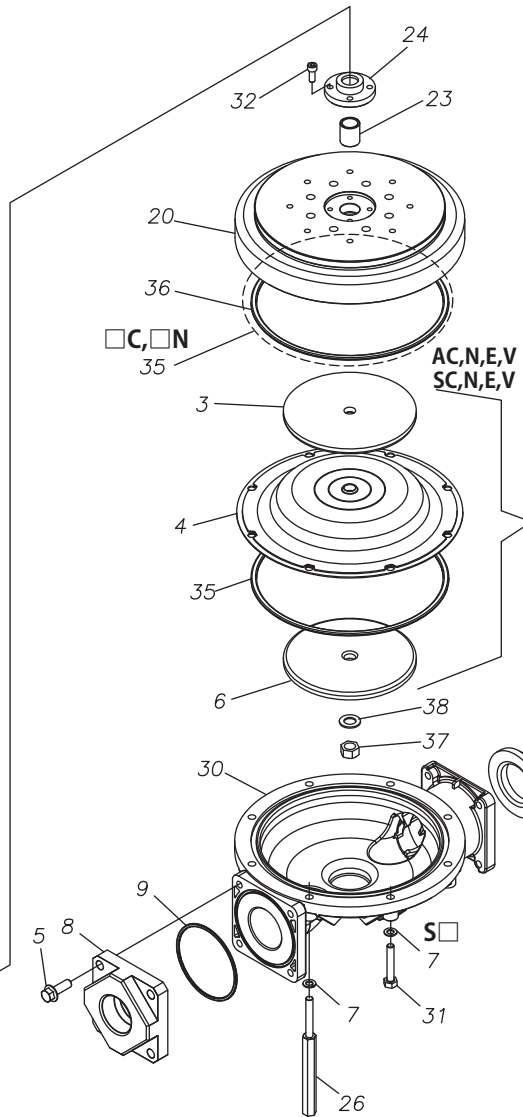
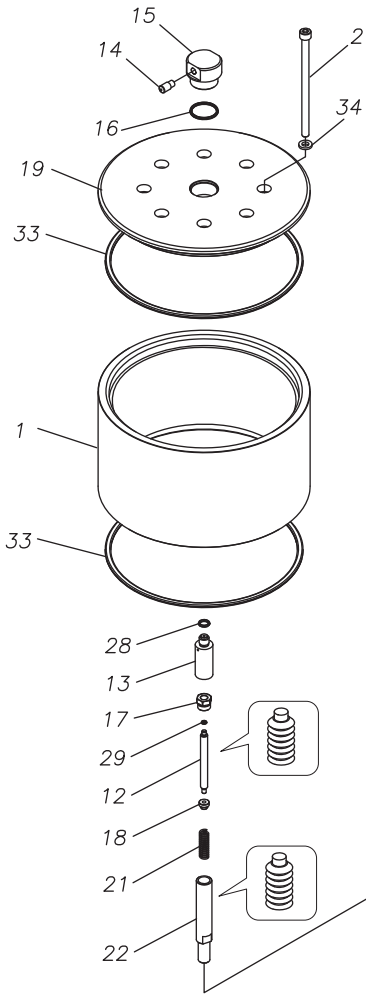

AH, AS, SH, SS

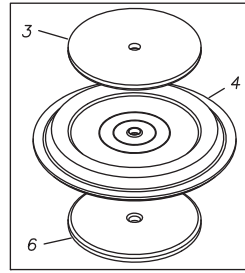

AT, ST

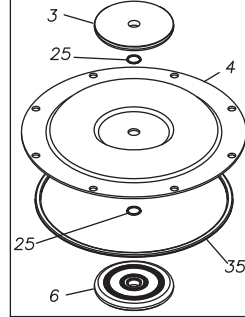

AW, SW

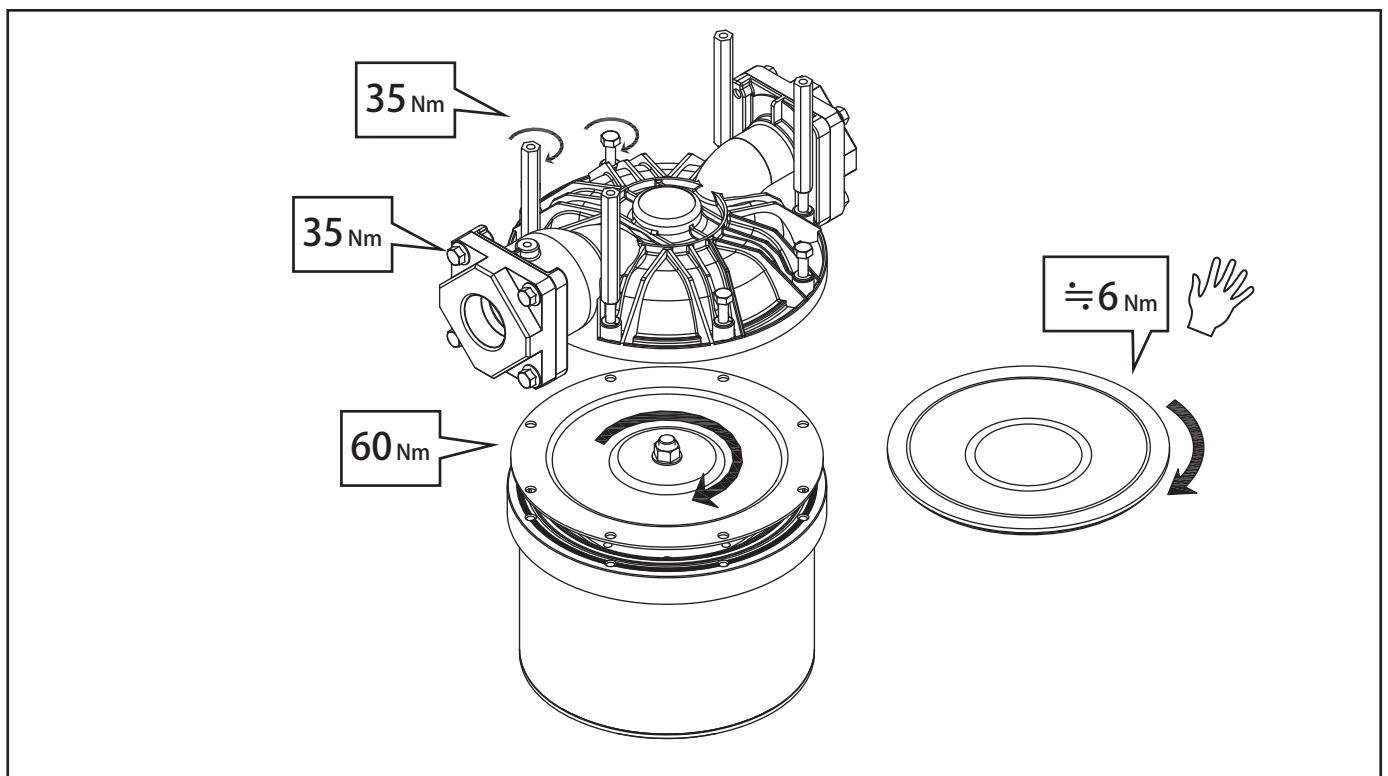
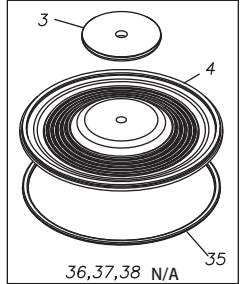

4 50G□ 50V□

4-10

